

RADIO CONTROLLED, ENGINE-POWERED, OFF-ROAD RACING BUGGY

CIRCUIT 1000 SERIES

STINGER 4WD

- THE SOPHISTICATION OF FOUR-WHEEL DRIVE IN A .10-CLASS ENGINE-POWERED BUGGY.
- RACE-PROVEN FOUR-WHEEL INDEPENDENT SUSPENSION WITH DOUBLE WISHBONES AND OIL-FILLED SHOCKS.
- DESIGNED FOR RELIABILITY, WITH TEMPERED STEEL DRIVE CHAIN, TOUGH EX66 NYLON AND ALUMINUM PARTS.
- FRONT AND REAR DIFFERENTIALS THAT DISTRIBUTE ENGINE POWER MOST EFFECTIVELY TO THE FOUR WHEELS FOR GREAT TRACTION AND POWER!
- KIT INCLUDES HANDY "ZIP" STARTER FOR USE WITH MOST .09-.11 MODEL ENGINES.
(ELECTRIC STARTER CAN ALSO BE USED.)
- EASY ASSEMBLY WITH CLEAR INSTRUCTIONS.
- SIMPLE ADJUSTMENTS FOR TOP HANDLING CHARACTERISTICS.
- A RACE-WINNING PERFORMER ON THE MOST DEMANDING TRACKS.
- THE BEGINNING OF A NEW ERA IN .10-SIZED ENGINE-POWERED BUGGIES!

1:10 SCALE

■ Radio: 2-Channel
Engine: .09-.11
(NOT INCLUDED)



KYOSHO
THE FINEST RADIO CONTROL MODELS

KIT No.3041

STINGER 4WD

Before you begin, carefully read through the manual. This will give you a better understanding of the construction of this model.

Check the parts in the kit. Check to see if all parts are correctly bagged as they are listed in the list of "Bagged Parts"

Check all components prior to the beginning of your assembly. Any claims for replacement, refunds or parts shortages for this kit after you have started to assemble it, will not be accepted.

O Certain symbols are used throughout the instructions. Pay attention to their location.

OIL ... Points where Grease/Oil should be applied. (This will reduce wear and friction and provide a smoother operating joint.)

SW-LOCK ... Places where Locktite (Zap Lock, ect.) should be applied. (This will prevent screws and nuts from loosening up during operation due to the vibration of the model.



Where you see this face, are steps that you should pay extra particular attention to when building this model.

IMPORTANT! BEFORE YOU BEGIN

A WORD OF WARNING is necessary, especially if this happens to be your first gas-powered vehicle. Gas-powered cars are subjected to stress and strain due to high engine RPM, rough terrain and the racing/high performance usage that they receive. As a result, they need continual preventative maintenance to keep them in operating condition.

This is a sophisticated model with a large number of moving parts. Before you begin assembly, take a look through the box and these instructions carefully to decide whether or not you are ready for this challenge! If you do not feel that this type of model is for you, it may be returned to the dealer as long as it is NEW and UNUSED. UNDER NO CIRCUMSTANCES CAN YOUR DEALER ACCEPT A KIT FOR RETURN IF ASSEMBLY HAS ALREADY BEGUN! If this is not what you bargained for, then go no further and return this kit to the dealer immediately. BUT, if a little maintenance doesn't bother you and the thrill of high performance driving is for you, then don't hesitate another minute! Read through this entire manual thoroughly to familiarize yourself with the parts and methods of construction before actually starting to build.

NOTE: Please refer to the instructions supplied by O.S. for your engine. Pay particular attention to the "Safety Instructions and Warnings"



ENTIRE CONTENTS
©COPYRIGHT 1986, HOBBICO, INC.

2 CHANNEL RADIO SYSTEM

A two channel, two servo radio control system is required for running the Stinger 4WD. The various components are pictured below.

TRANSMITTER

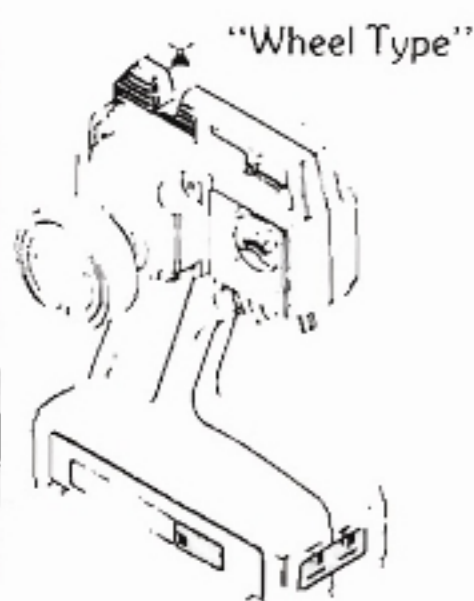

"Wheel Type"

"Stick Type"

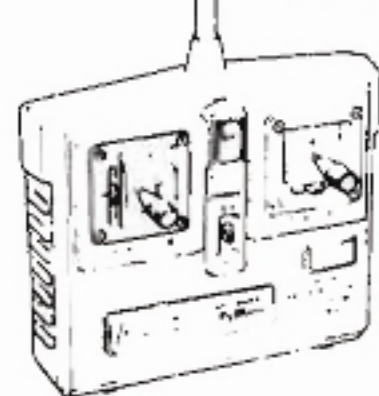

Note: use only radio frequencies specifically allowed to operate "surface" models such as R/C cars and boats. In the United States those frequencies fall within the "75 MHz" or "27 MHz" bands. Use of any other frequencies is both illegal and dangerous.

On Pages 20 and 21 there is a guide for the small parts used in each step. Simply cut out the sheet along the dotted line and use it to help you locate the particular parts and their shape used in each step.



RECEIVER

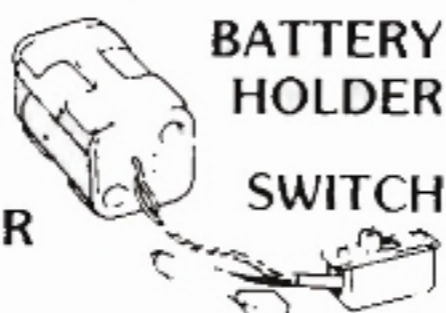

BATTERY HOLDER
SWITCH

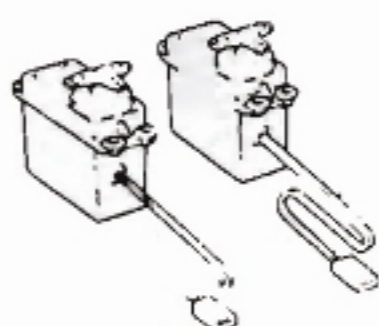

SERVOS

REQUIRED TOOLS

These are not included with the Stinger.

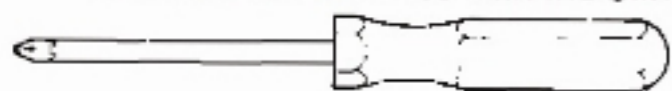

FLAT HEAD SCREW DRIVER

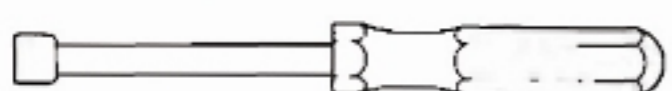

NUT DRIVER (4mm) or equivalent



HOBBY KNIFE

NEEDLE NOSE PLIERS

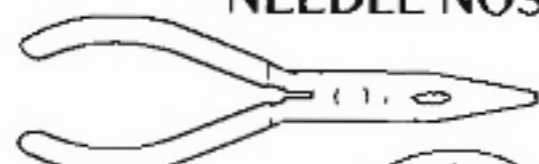

HOBBY SHEARS



BODY SANDER

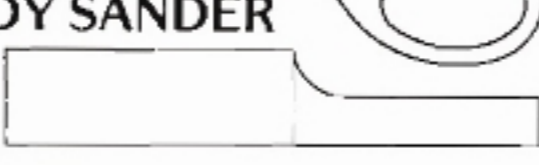

A few different types of screws are used in the construction of your model. Here are some examples of them and how they will be indicated in the instructions. For example, Self Tapping will simply be S/T screw.

SCREW

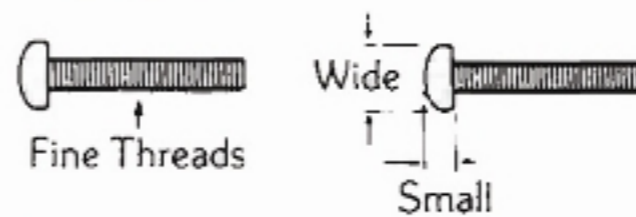

If it is an ordinary screw it will be marked "screw".

ALLEN HEAD SCREW (A/H)

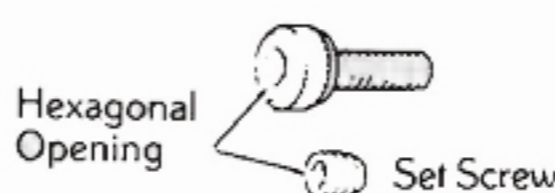

SELF TAPPING (S/T)

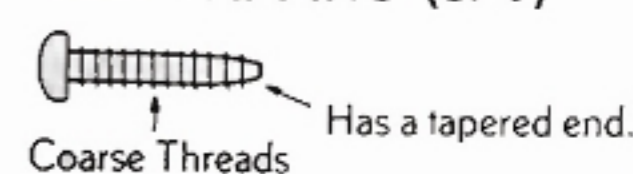

FLAT HEAD SCREW (F/H)

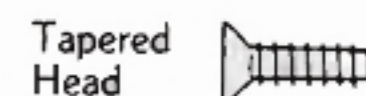

PAN HEAD SCREW (P/H)

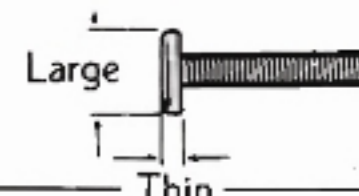

METRIC NUTS AND BOLTS

All nuts and bolts used throughout this kit are metric size. Therefore, some of the notations may not be familiar to you. An M3 nut is a 3 millimeter (3mm) nut). An M3x15 screw is 15mm long and 3mm in diameter. Some round parts may be labeled as a "4 0

M3x15 SCREW

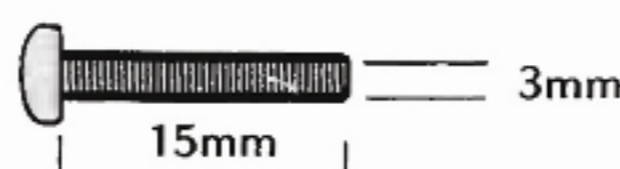

4 0 WASHER

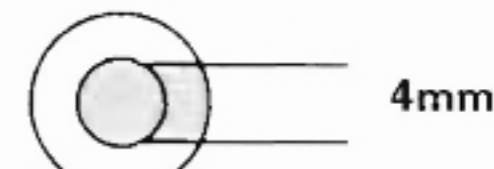

Washer" (this should be a washer with a 4mm inside diameter) or a "3 0 Bushing" (a bushing with a 3mm inside diameter). At various point throughout the manual these parts are labeled and pictured in their actual size on the left hand side of the page. For your reference, 1 millimeter equals approximately .039 inches.

Use the list of small parts to compare the shapes of the small parts used with each step such as screws, nuts and washers.

Do not use excessive force when tightening S/T type screws into plastic. Overtightening will cause the threaded portion of the plastic to strip. It is recommended to stop tightening when some resistance is felt after the threaded portion enters the plastic.

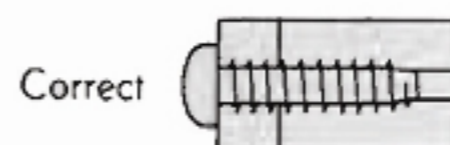

Correct

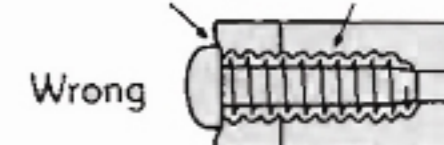

Wrong

BALL BEARINGS



Ball Bearings greatly improve performance and reduce maintenance. A complete set of optional bearings for your Stinger is available. The H-003 bearing set contains (10) 5mmx10mm and (4) 4mmx8mm ball bearings.

ELECTRIC STARTER

If you choose to use an electric starter instead of the "Zip Starter" you will need the items shown below.



12V POWER SOURCE



ELECTRIC STARTER



12V CHARGER

Items you will need for running the Stinger 4WD.



FUEL BULB
To fill fuel tank.

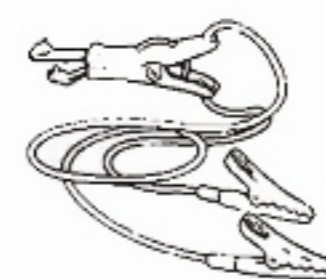

GLOW PLUG
BATTERY CORD



A GOOD QUALITY glow fuel is very important. Choose a blend with a 10-25% nitro-methane content.



To start the engine, a 1.5V battery will be used to heat the glow plug.

REQUIRED TOOLS

These are not included with the Stinger.

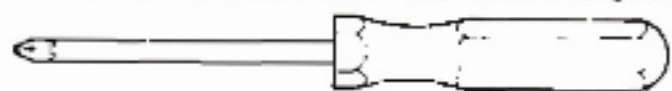

FLAT HEAD SCREW DRIVER

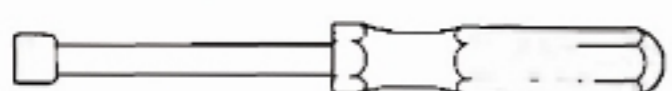

NUT DRIVER (4mm) or equivalent



HOBBY KNIFE

NEEDLE NOSE PLIERS

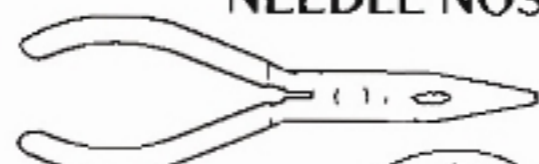

HOBBY SHEARS



BODY SANDER

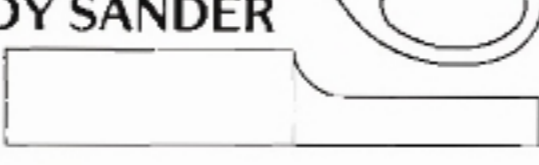

AWL



4-WAY
WRENCH



CYANOACRYLATE
GLUE

POLYCA PAINT



BRUSH

MASKING TAPE



1 INSTALLATION OF JOINT

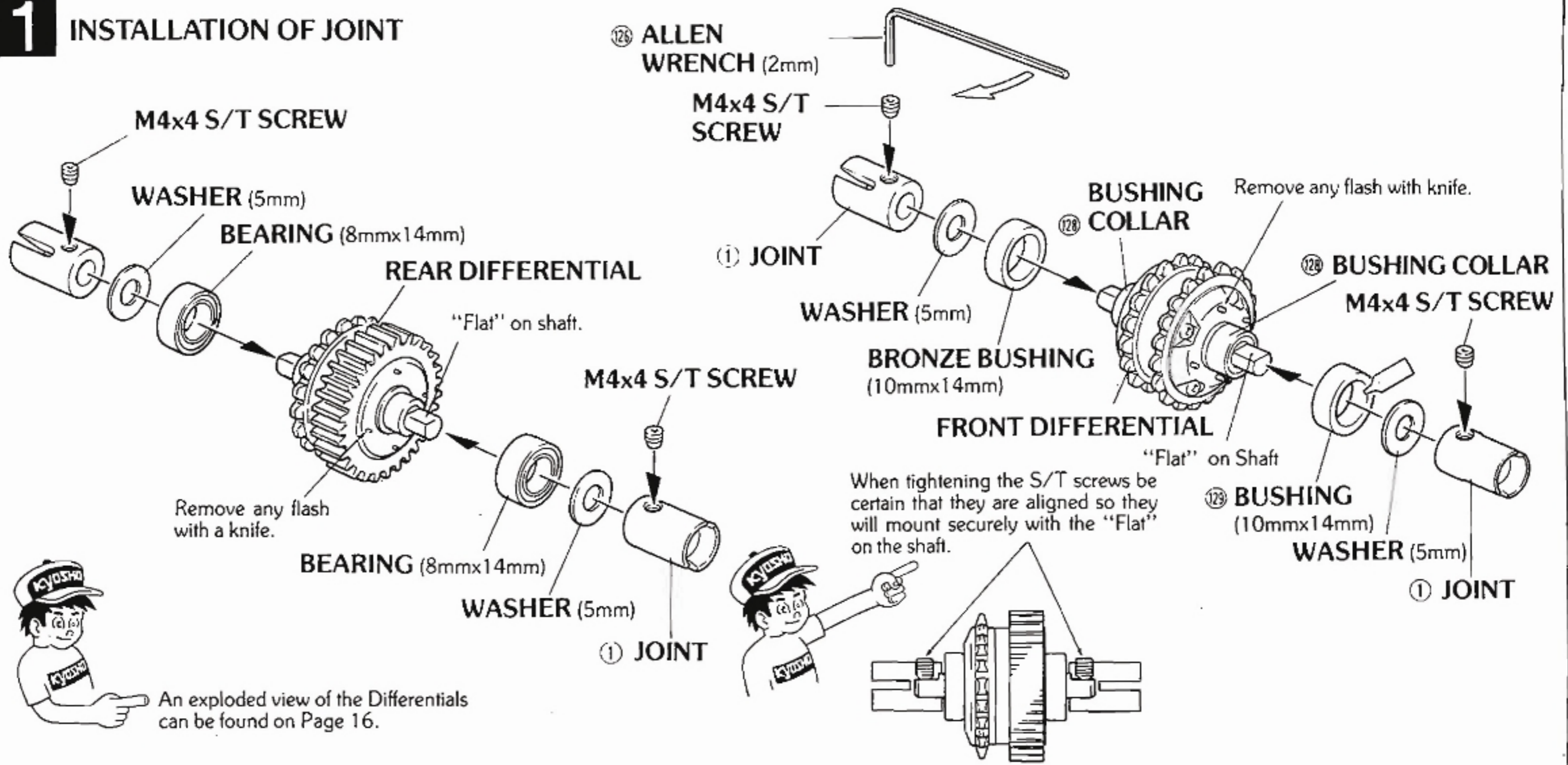

2 ASSEMBLY OF REAR GEAR BOX

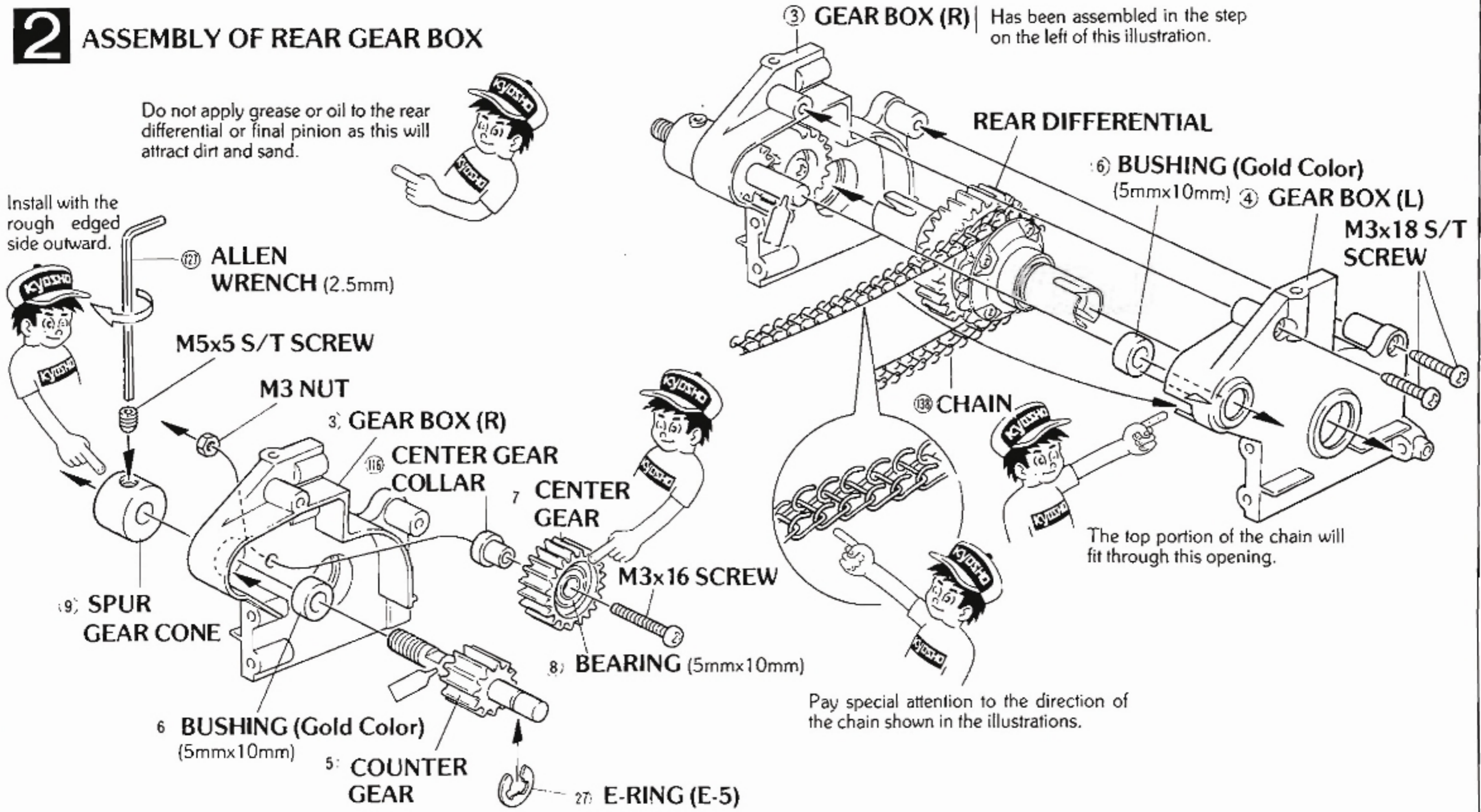

3 INSTALLATION OF REAR PLATE

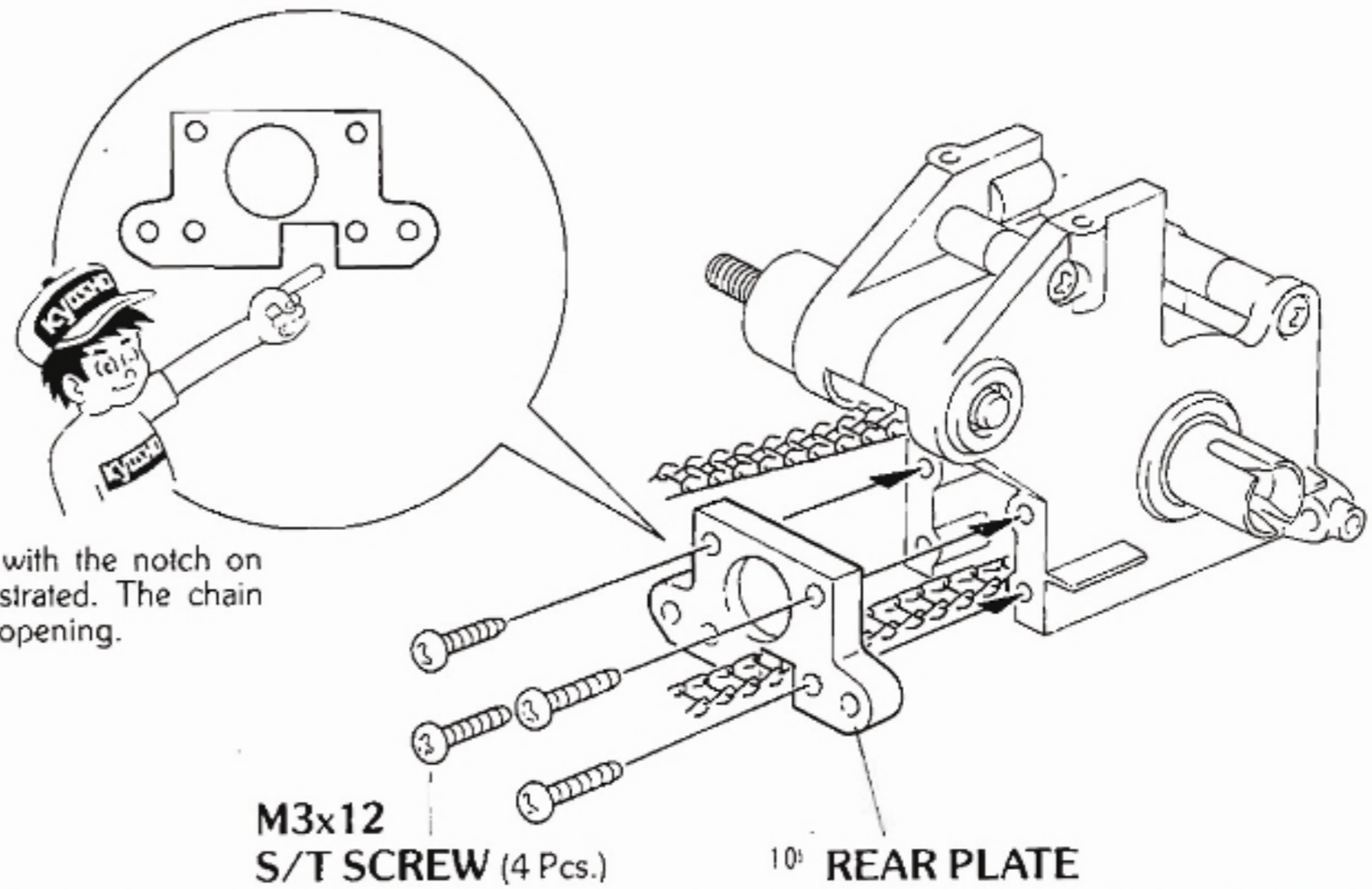

4 INSTALLATION OF SHOCK STAYS

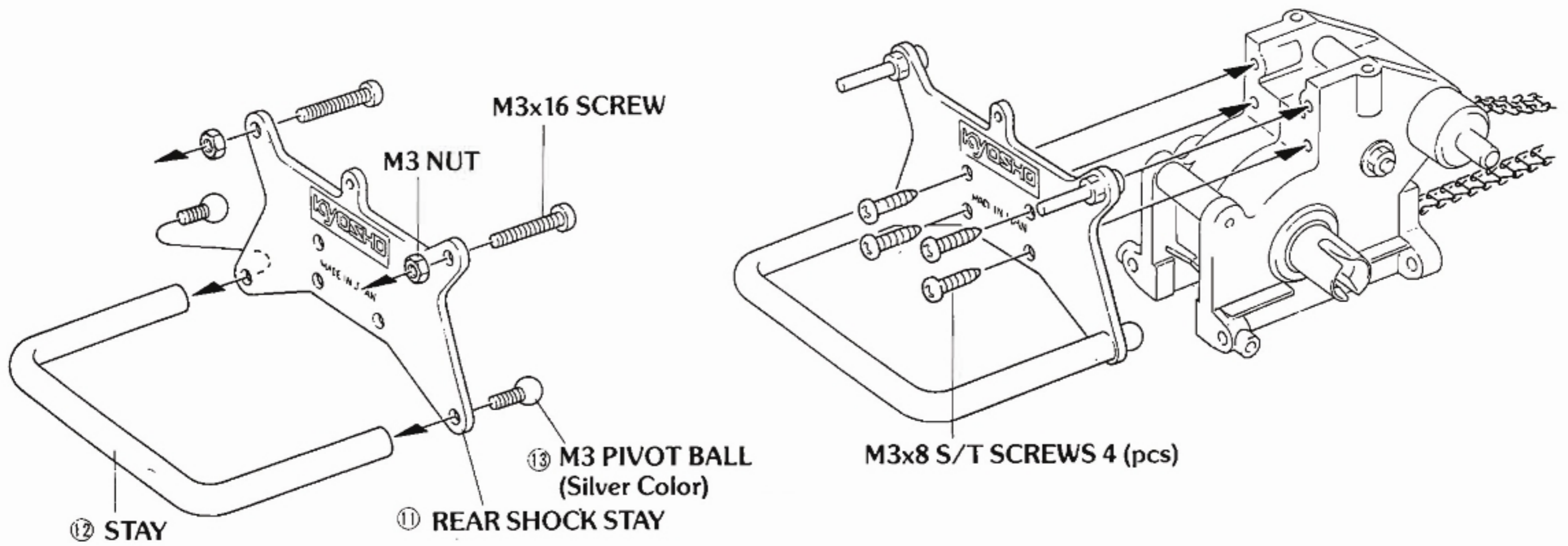

5 INSTALLATION OF FRONT GEAR BOX

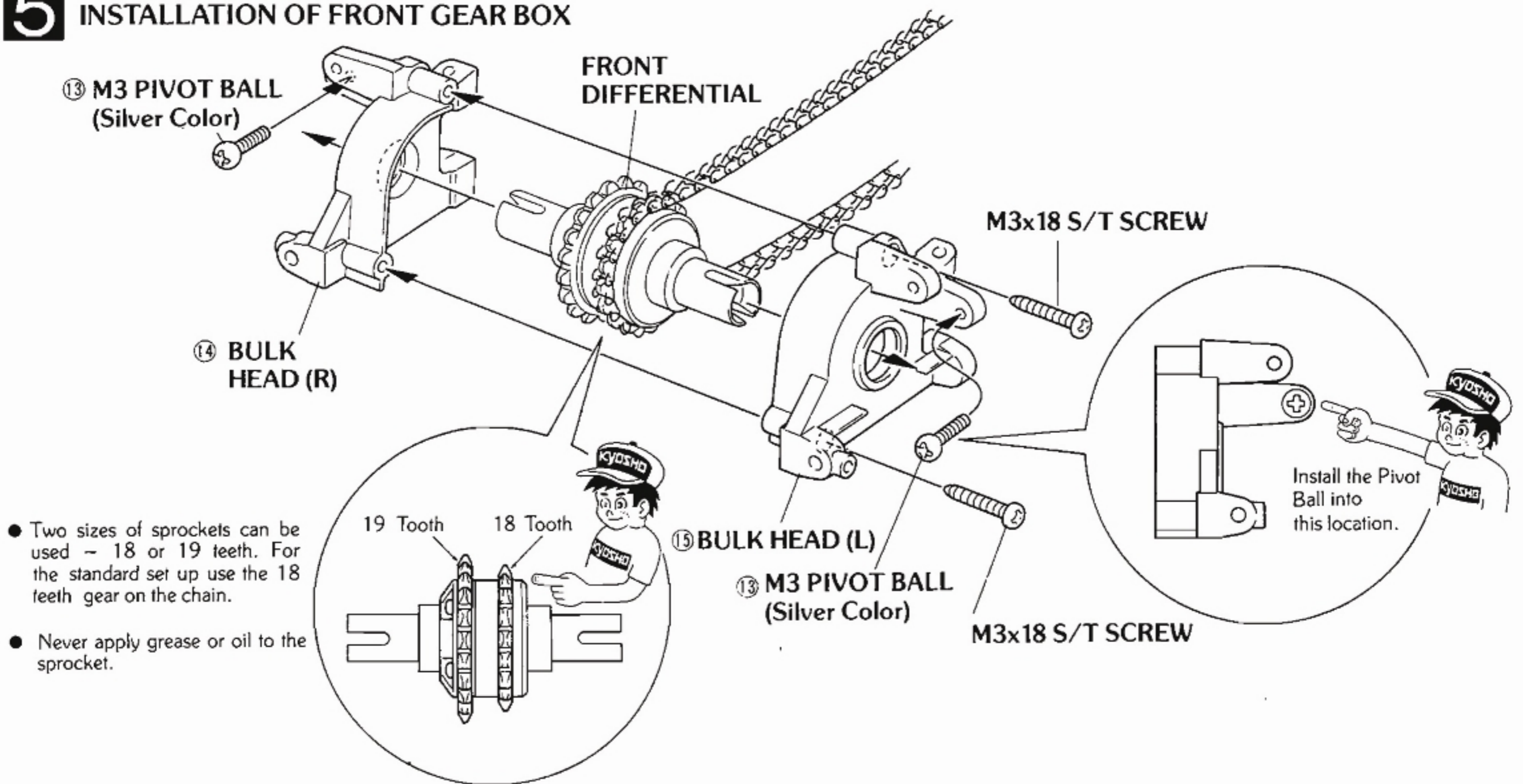

- Two sizes of sprockets can be used - 18 or 19 teeth. For the standard set up use the 18 teeth gear on the chain.
- Never apply grease or oil to the sprocket.

6 INSTALLATION OF FRONT SUSPENSION ARM

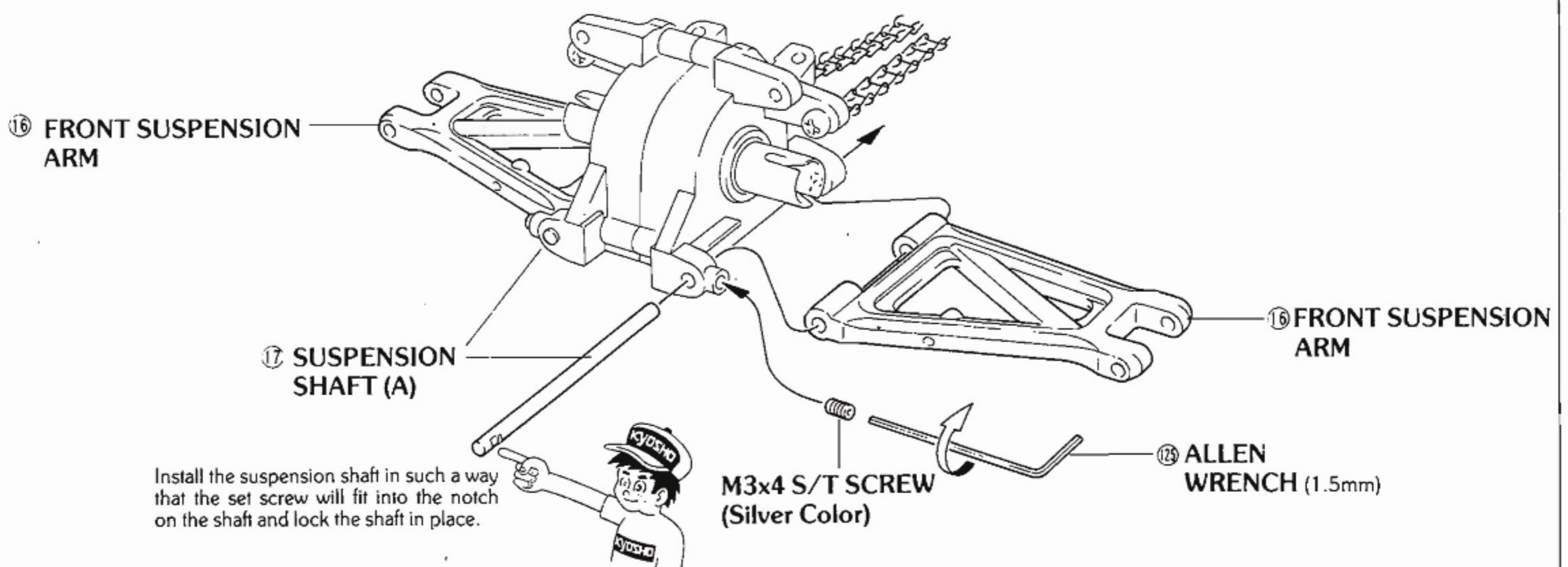

7 INSTALLATION OF CHASSIS

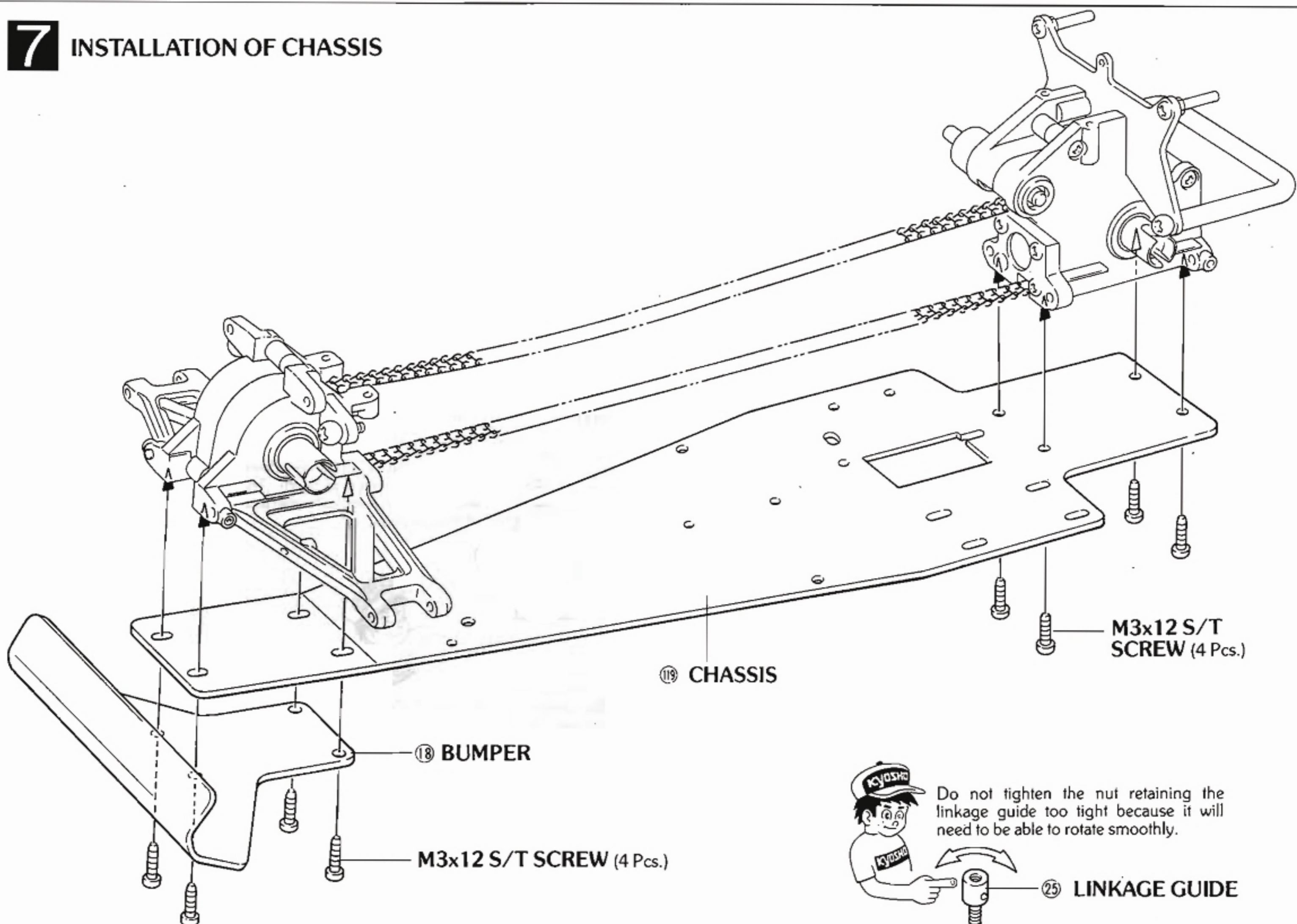

8 ASSEMBLY OF SERVO SAVER

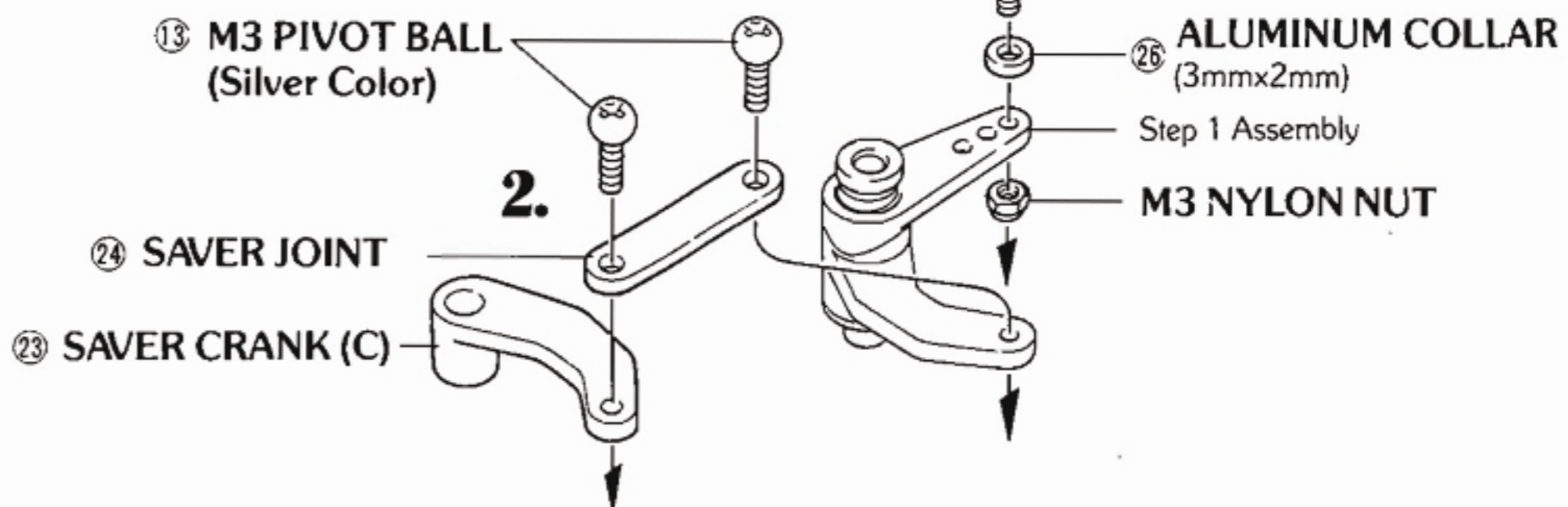
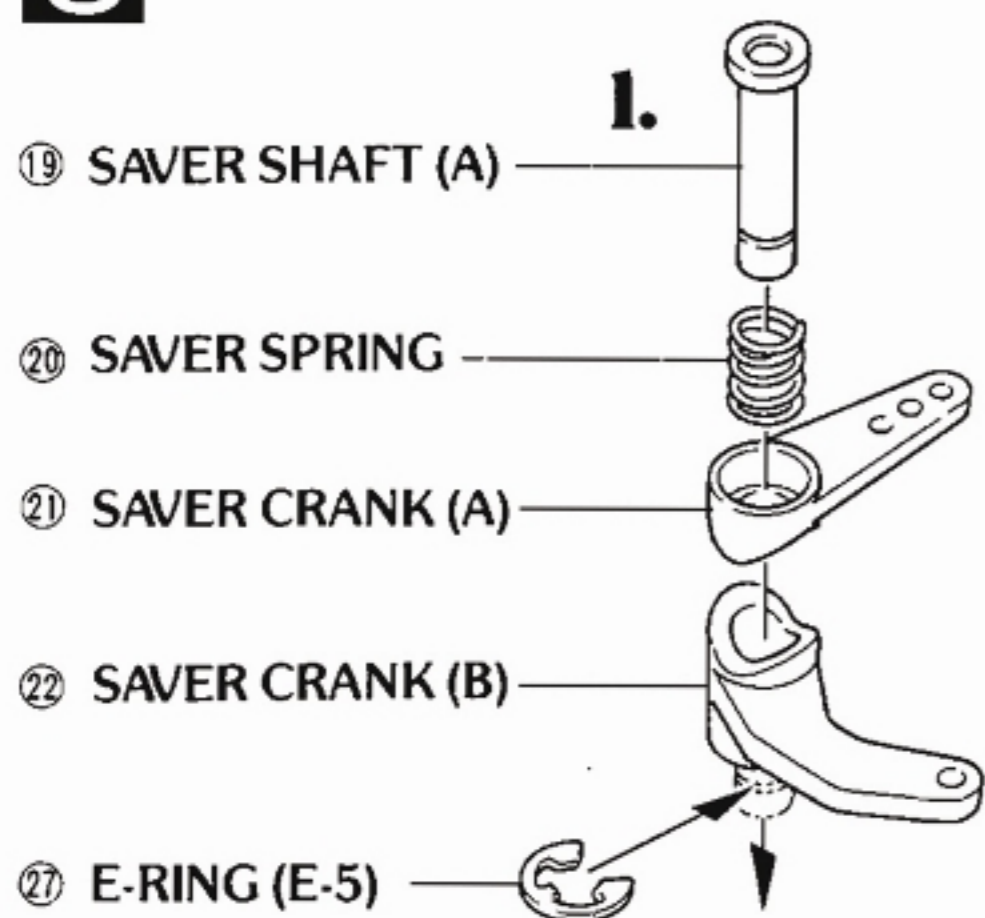

9 INSTALLATION OF SERVO SAVER

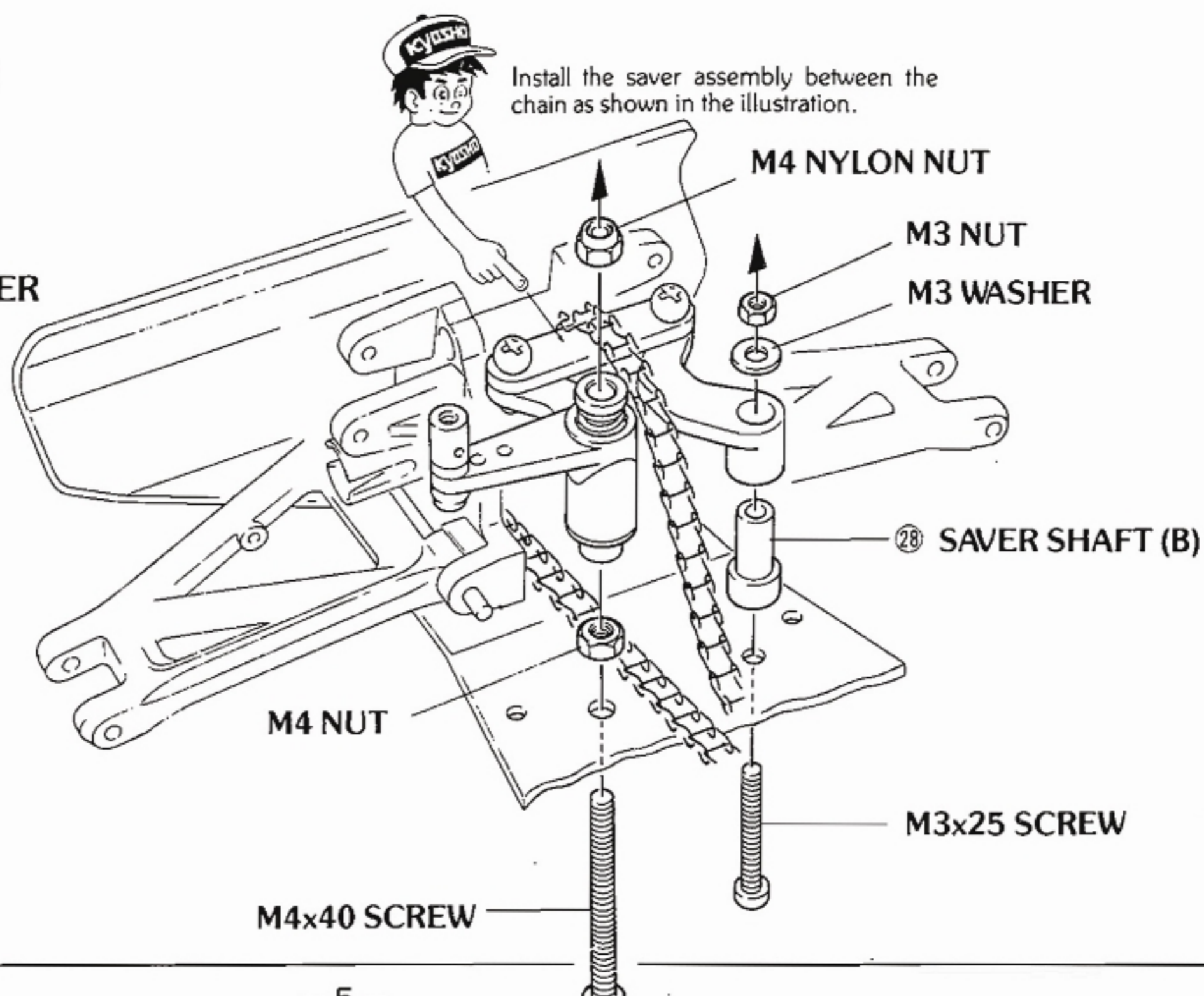

10 ASSEMBLY OF KNUCKLE ARM

1. Be certain to use the hub marked "L" when assembling the left side.

2. Do not tighten all of the way down. Leave a clearance of 1mm. This will allow for a smooth operation of the ball ends.

Be certain to use the hub marked "R" for the right side.

③① FRONT SHAFT

③① KNUCKLE ARM (L)

③① BUSHING (Black Color) (5mmx10mm)

③② M2.6 PIVOT BALL (Black Color)

③③ KING PIN

③④ M2.6 NUT

③⑤ M3 PIVOT BALL (Silver Color)

③⑥ FRONT HUB (L) (Plastic)

③⑦ FRONT HUB (R) (Plastic)

③⑧ KNUCKLE ARM (R)

11 INSTALLATION OF KNUCKLE ARM

Using needle-nose pliers, attach the E-ring to the suspension shaft.

This is the left knuckle arm that was assembled in step 10

③⑦ E-RING (E-2.5)

③⑧ KNUCKLE ARM (L)

③⑨ KNUCKLE ARM (R)

③⑩ SUSPENSION SHAFT (B) (Silver Color)

12 INSTALLATION OF FRONT UPPER ROD

Two ball end/upper rod assemblies will need to be made (one for each side).

This is the upper rod that has been assembled in the illustration to the left.

The left side is installed the same way as the right.

Note! The swing shaft must be simultaneously inserted while installing the upper rod assembly.

③⑧ BALL END (LG)

③⑨ UPPER ROD

(Actual Size)

57mm

③⑩ SUSPENSION SHAFT (B) (Silver Color)

③⑪ SWING SHAFT

13 FILLING THE SHOCKS WITH OIL

1. Remove stopper and fill shock case with oil up to the line as shown in the illustration below.

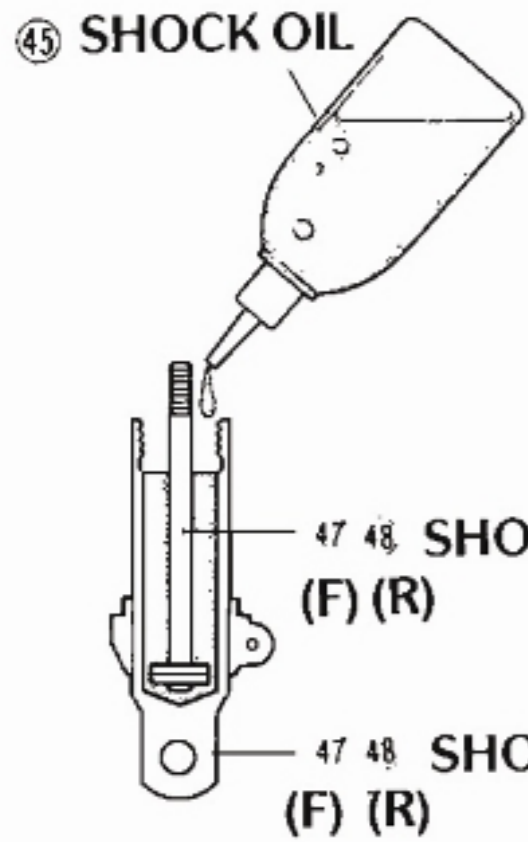

41 SHOCK END

2. Install the O-Ring and seal as shown.

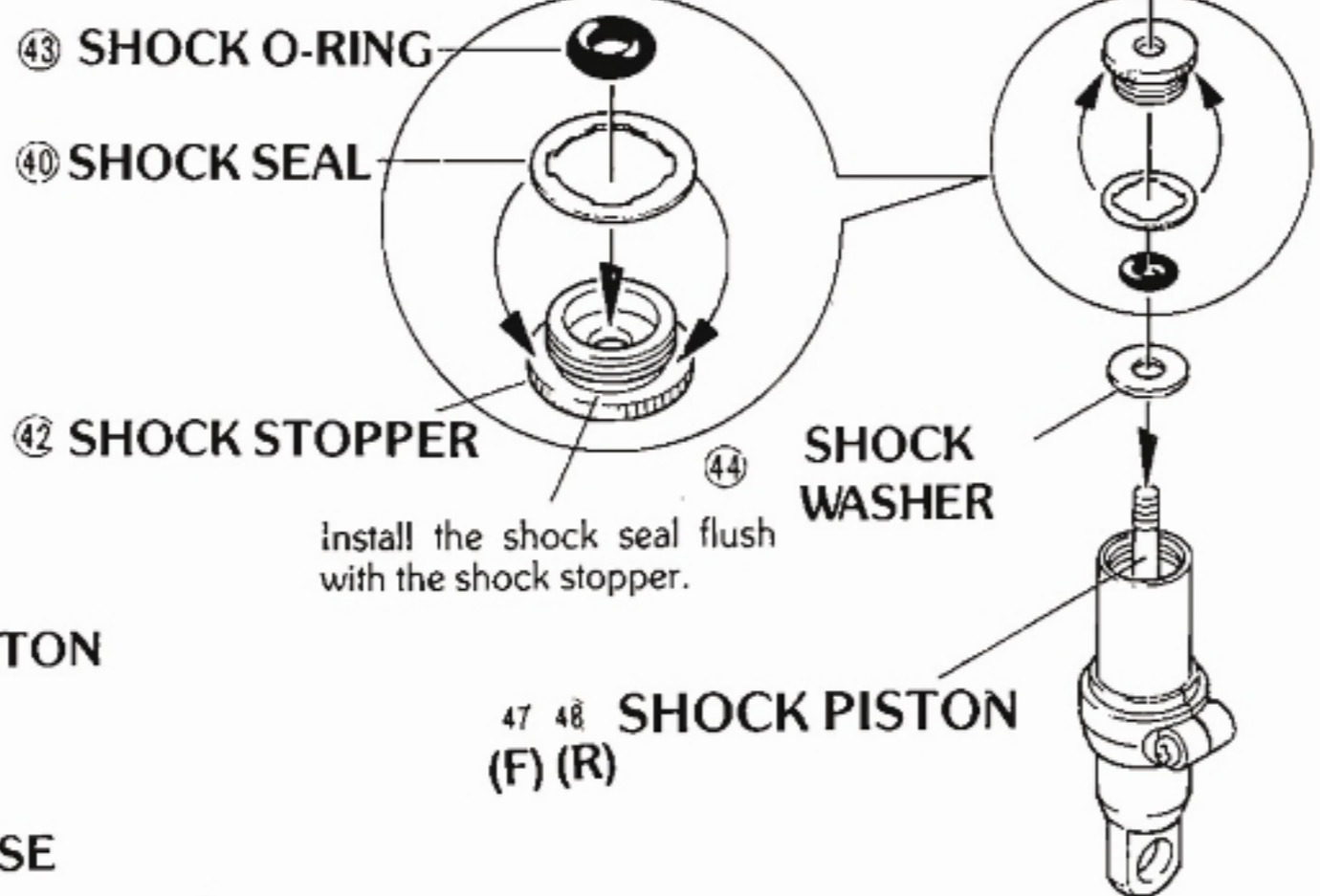

3. Using the shock wrench and an allen wrench as shown, tighten the shock stopper firmly against the shock case.

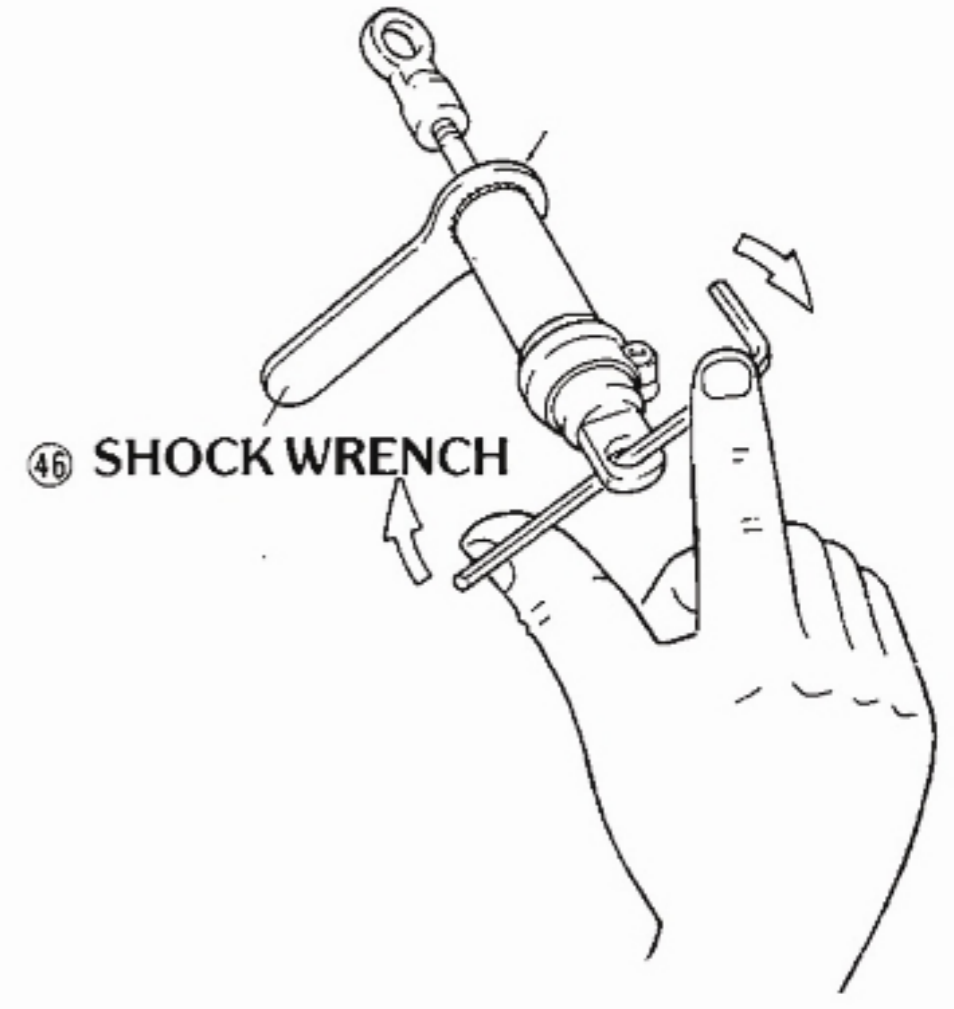

When installing the shock ends be certain that the front shocks are the same length as each other and that the rear shocks are the same length as each other.



Check the level of fluid in the case to see that it is at the proper level and that the shock can operate smoothly.

14 INSTALLATION OF FRONT SHOCK

It may easier to install the M3x12 screw with bushing first then snap the shock end onto the pivot ball.

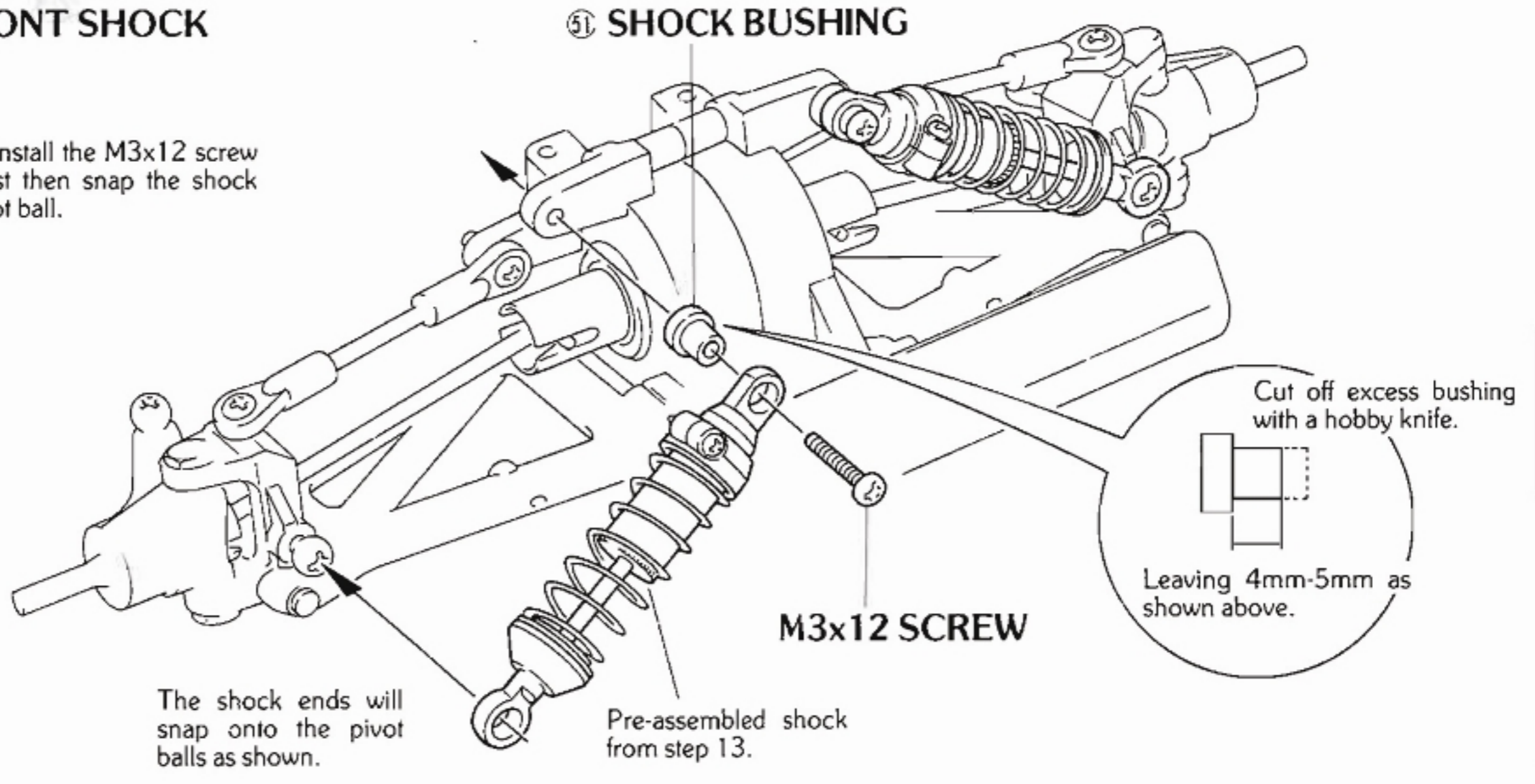

The shock ends will snap onto the pivot balls as shown.

Pre-assembled shock from step 13.

15 INSTALLATION OF THE ROD

Two tie rods (one for each side) will need to be assembled.

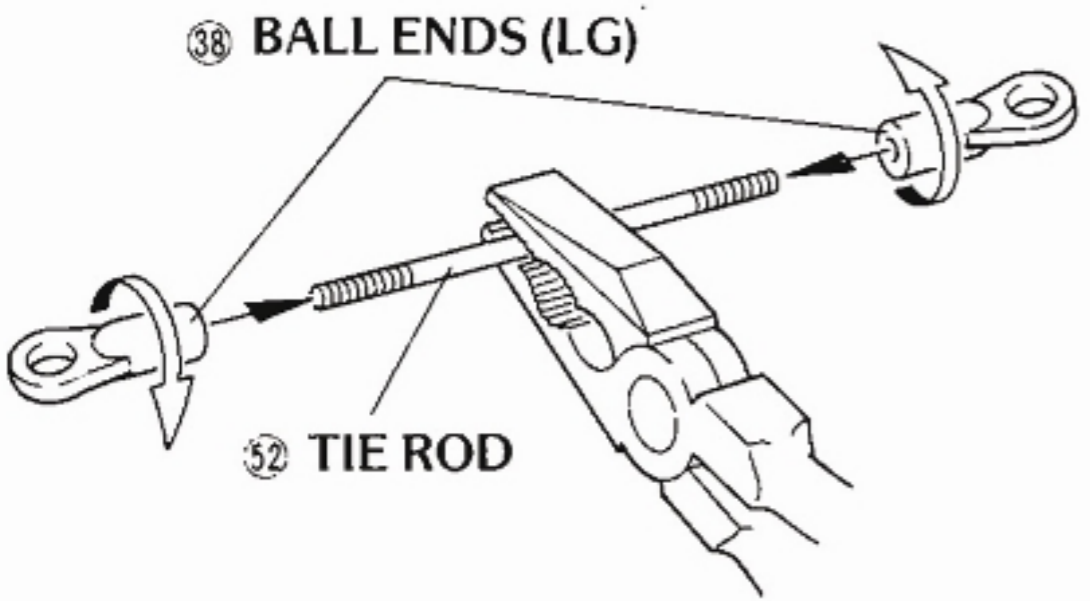

Install the tie rods by simply snapping the ball ends onto the appropriate pivot balls as shown.

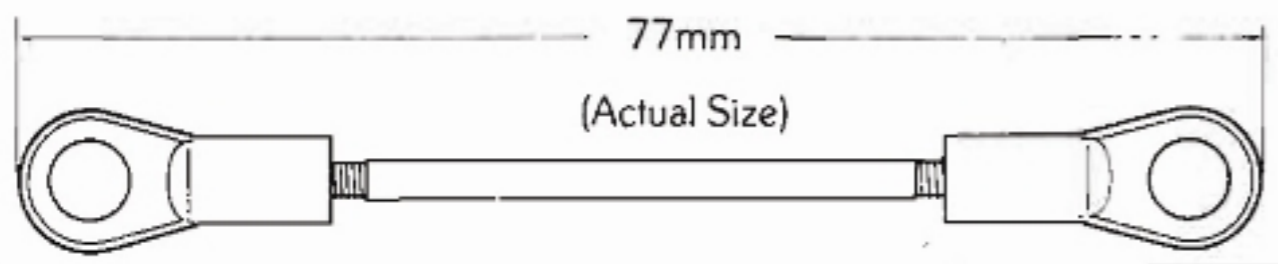
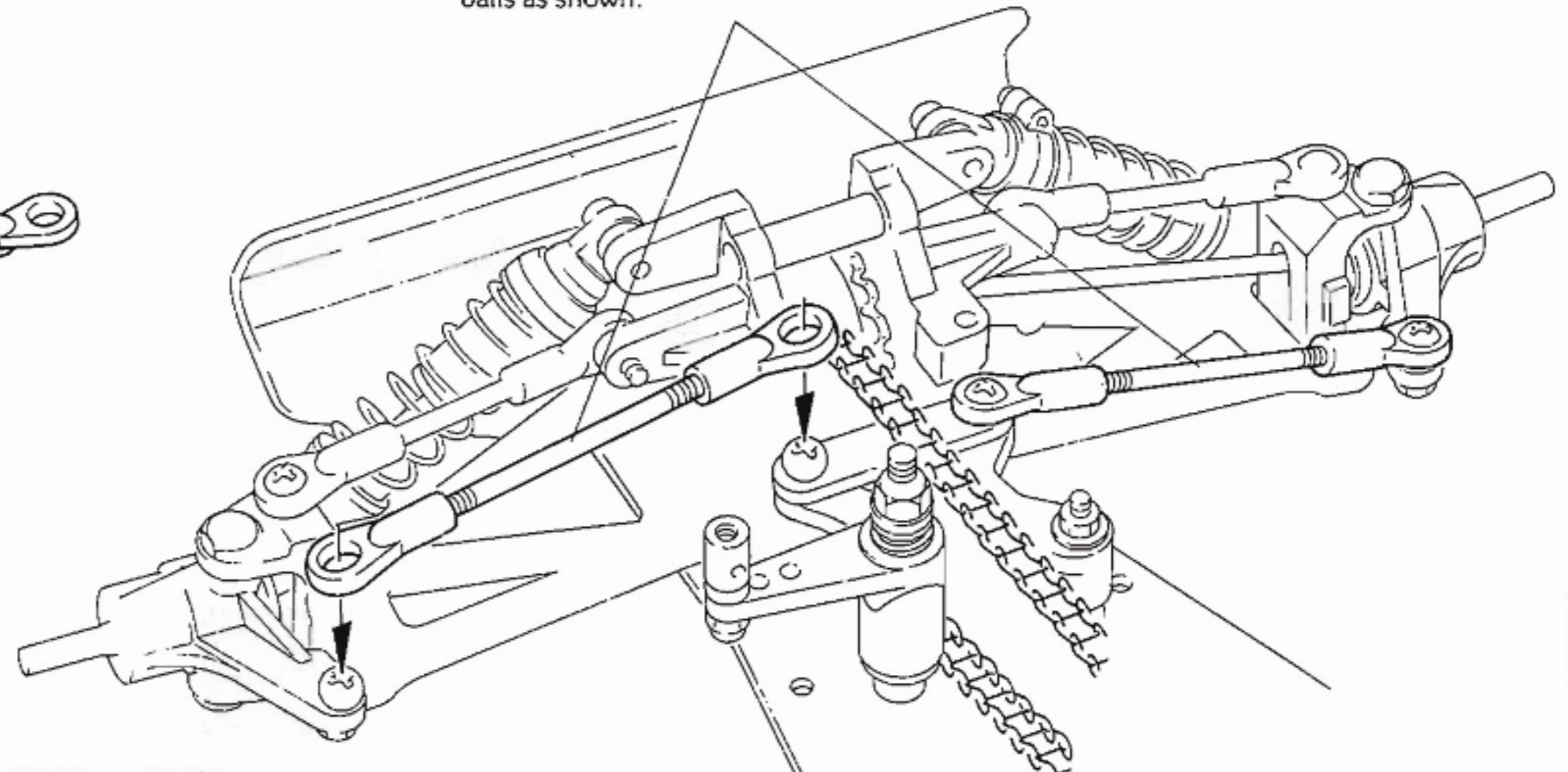

16 INSTALLATION OF REAR HUBS

⑬ BUSHING (Black Color)
(5mmx10mm)

⑤③ REAR SHAFT

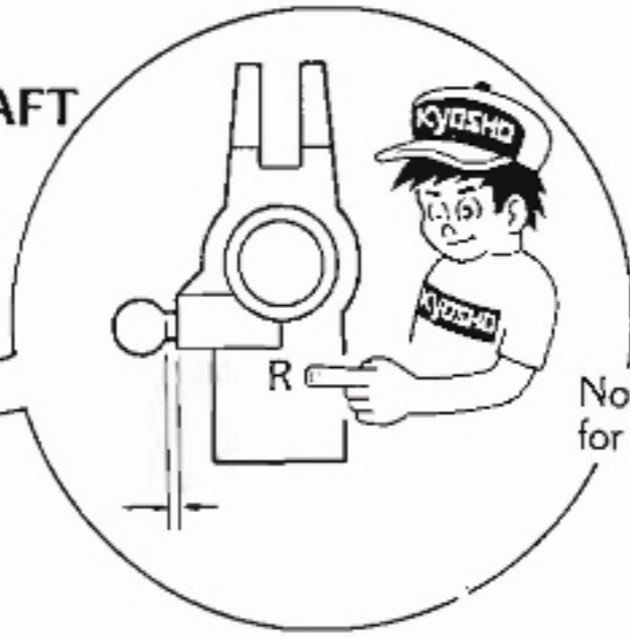

⑤④ REAR HUB (L)
(Plastic)

⑤⑤ REAR HUB (R)
(Plastic)

⑬ M3 PIVOT BALL
(Silver Color)

⑤⑥ REAR SUSPENSION
ARM

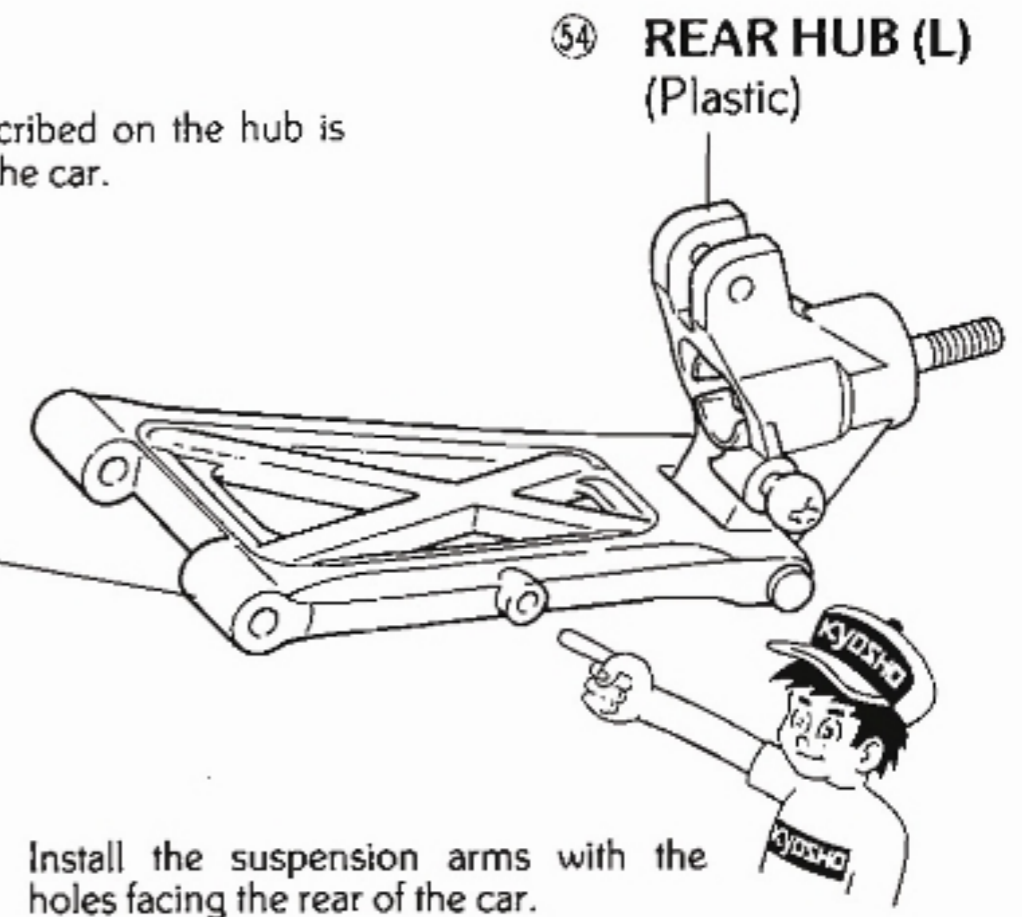

③⑦ E-RING (E-2.5)

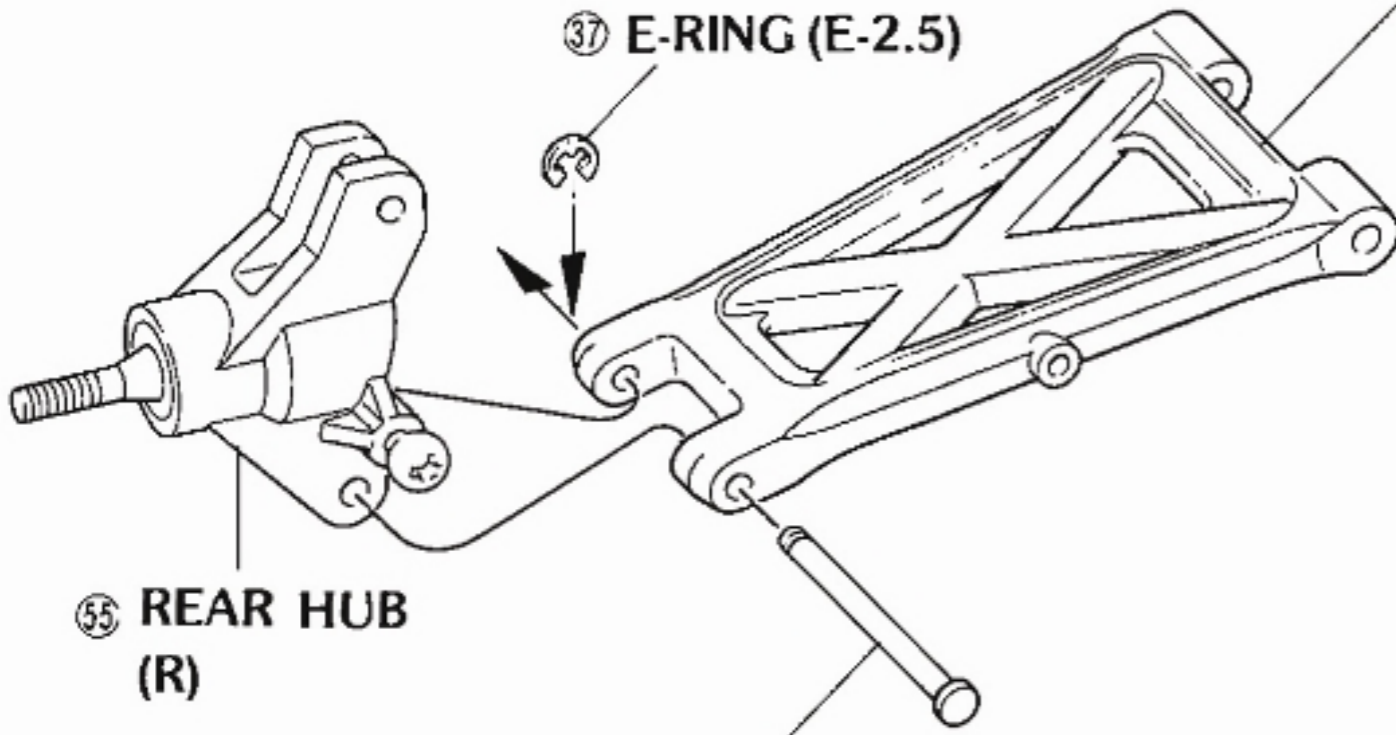

③⑦ SUSPENSION SHAFT (C)
(Black Color)

17 INSTALLATION OF REAR SUSPENSION ARMS

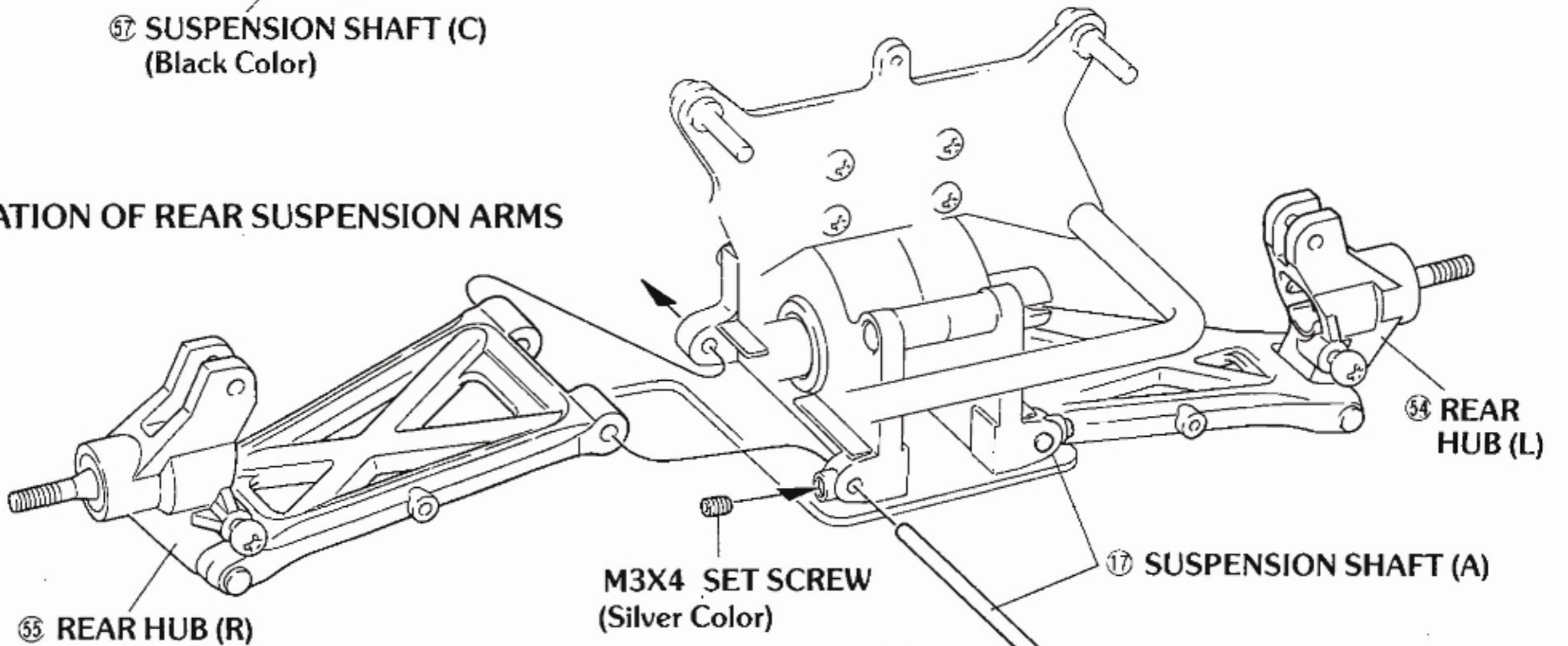

Install the suspension shaft in such a way that the set screw will fit into the notch on the shaft and lock the shaft in place.



The right side is installed the same as the left.

18 INSTALLATION OF REAR UPPER RODS

③⑧ BALL ENDS (LG) ③⑨ 5.8mm BALL

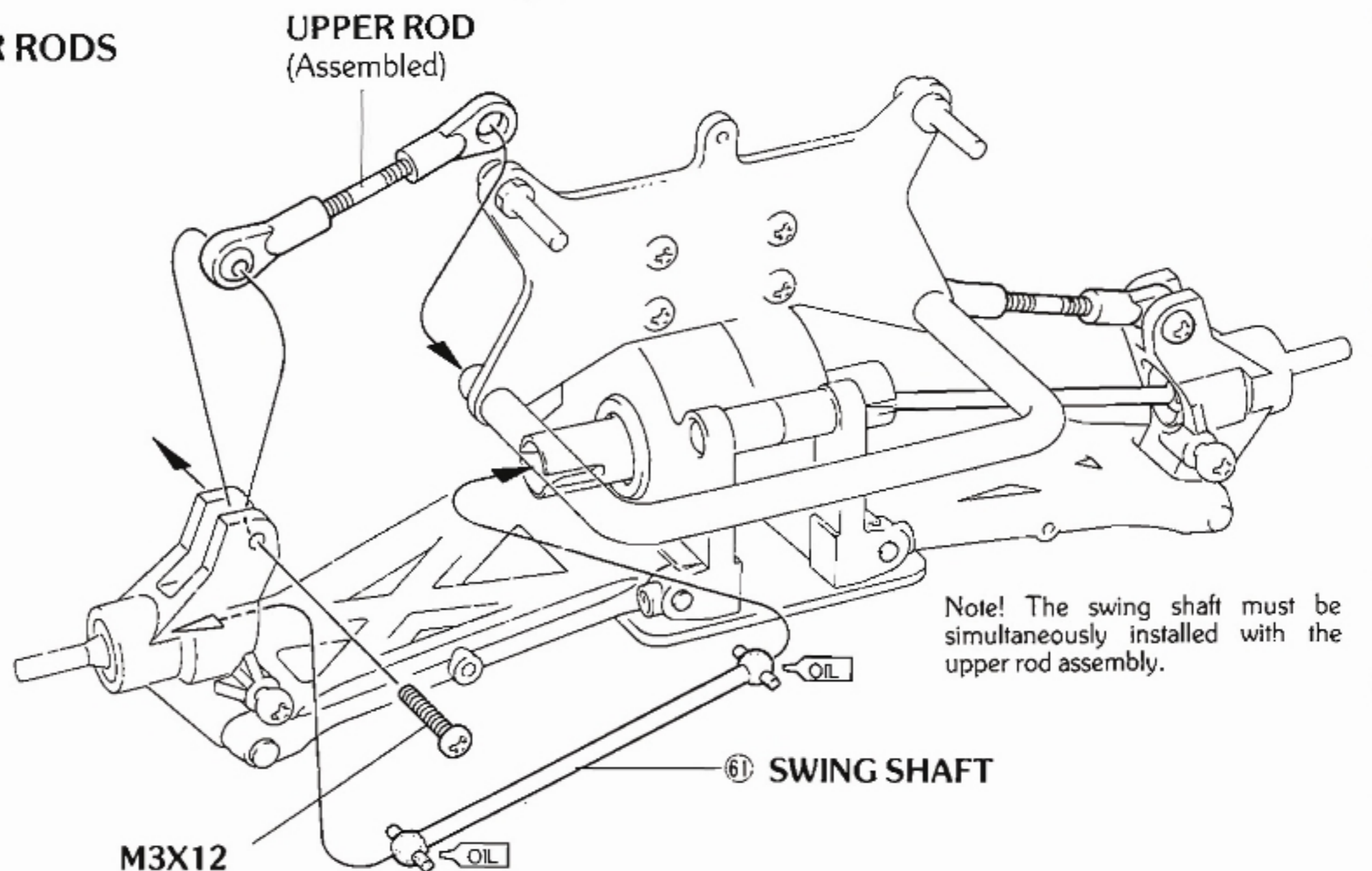
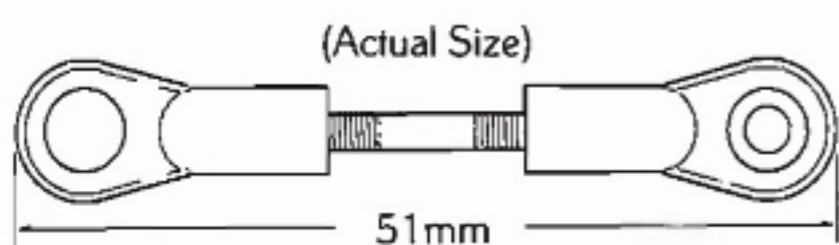
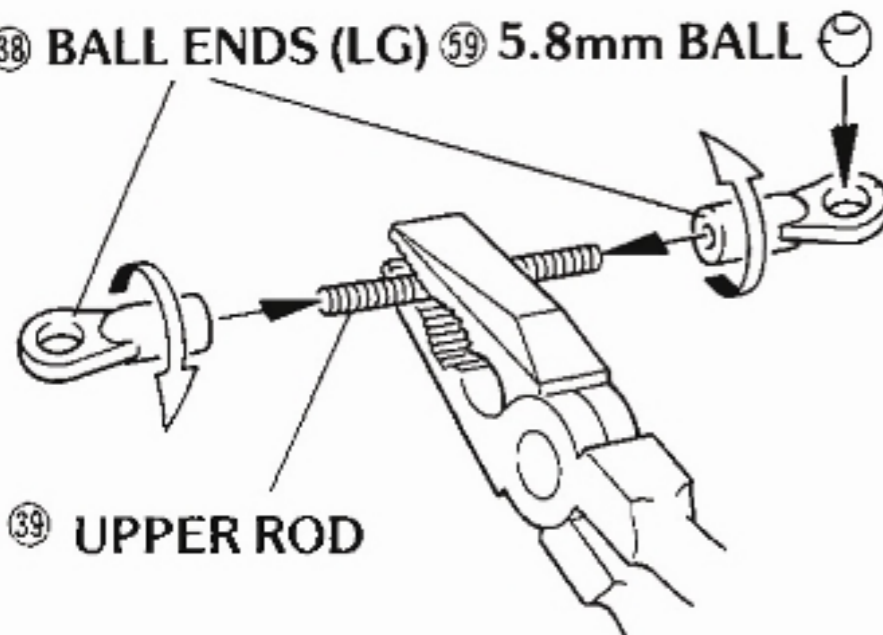

Note! The swing shaft must be simultaneously installed with the upper rod assembly.

19 INSTALLATION OF REAR SHOCK

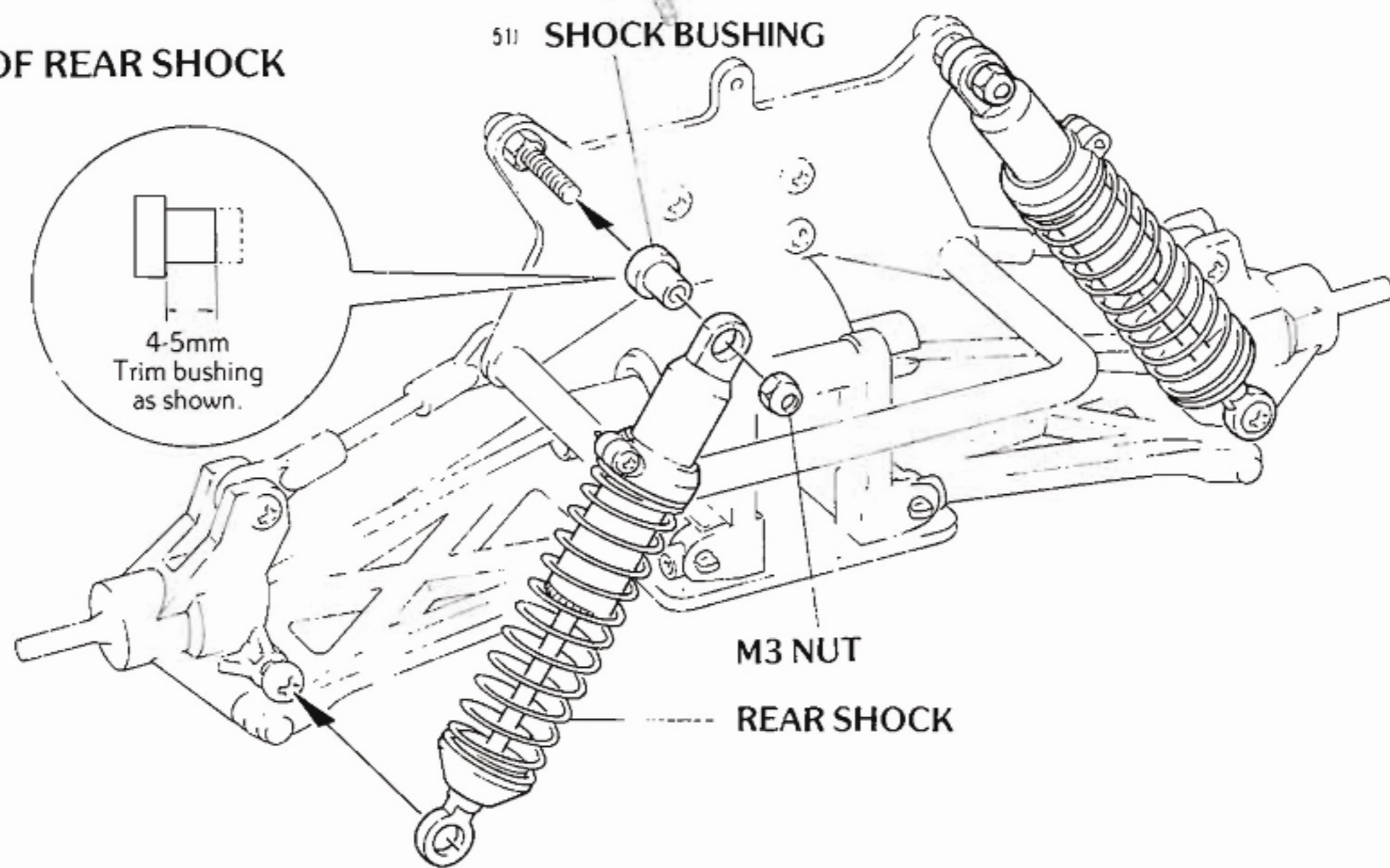

20 MOUNTING THE WHEEL & TIRE

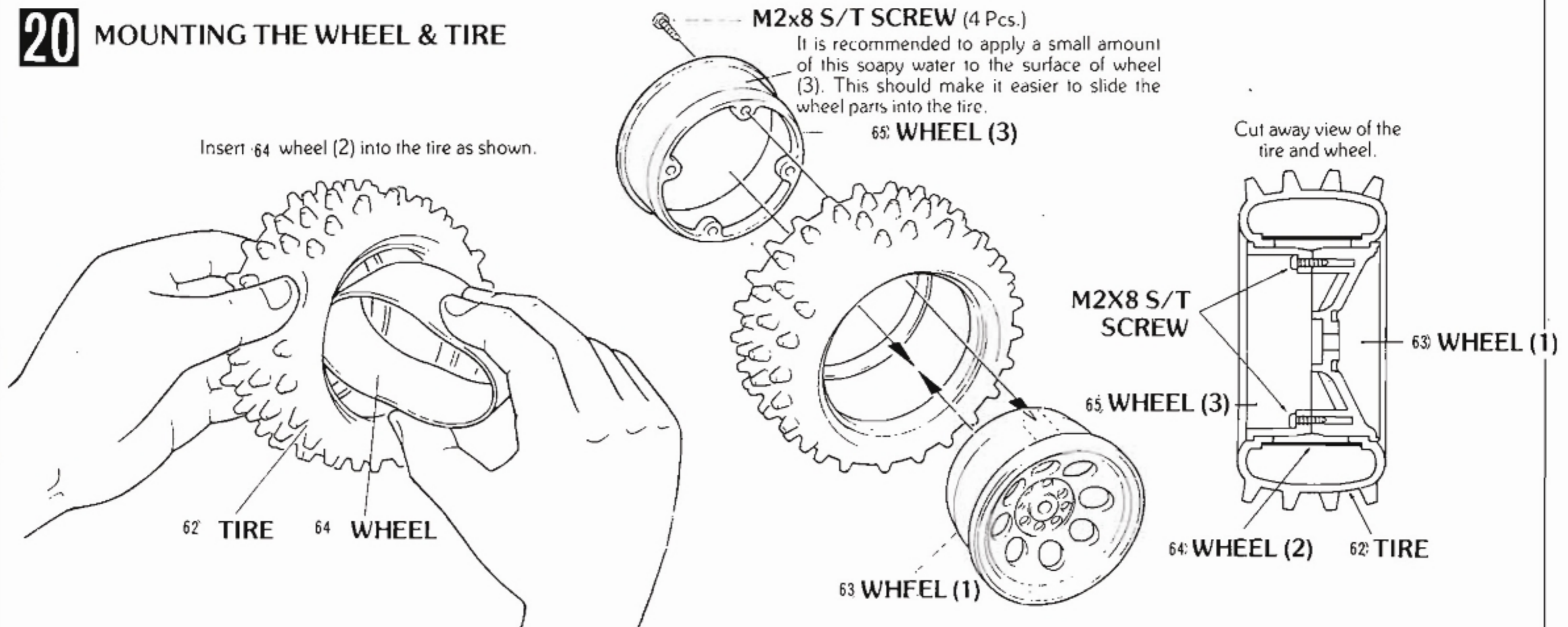

21 INSTALLATION OF TIRES AND SPUR GEAR

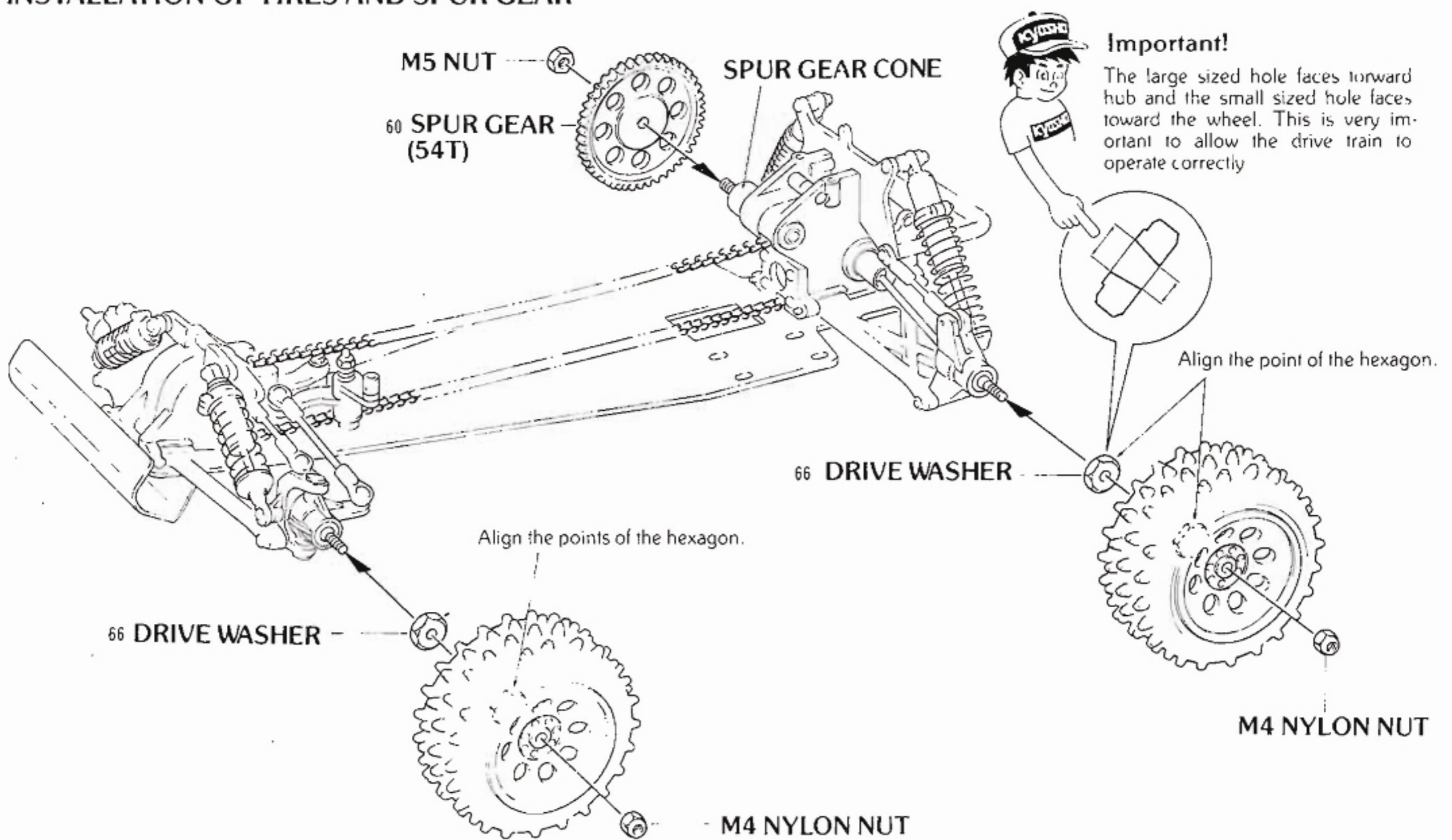

22 ASSEMBLY OF FLYWHEEL

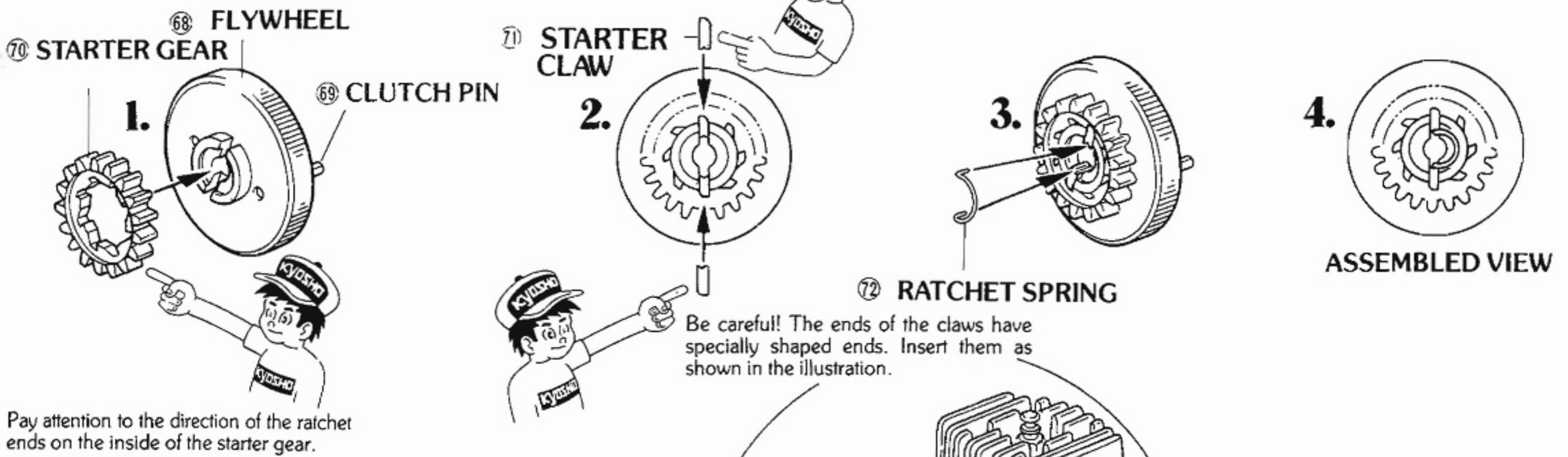

23 INSTALLATION OF ENGINE MOUNT FOR ENYA

- If you are using the Enya 11CX engine, follow steps 1 through 5.

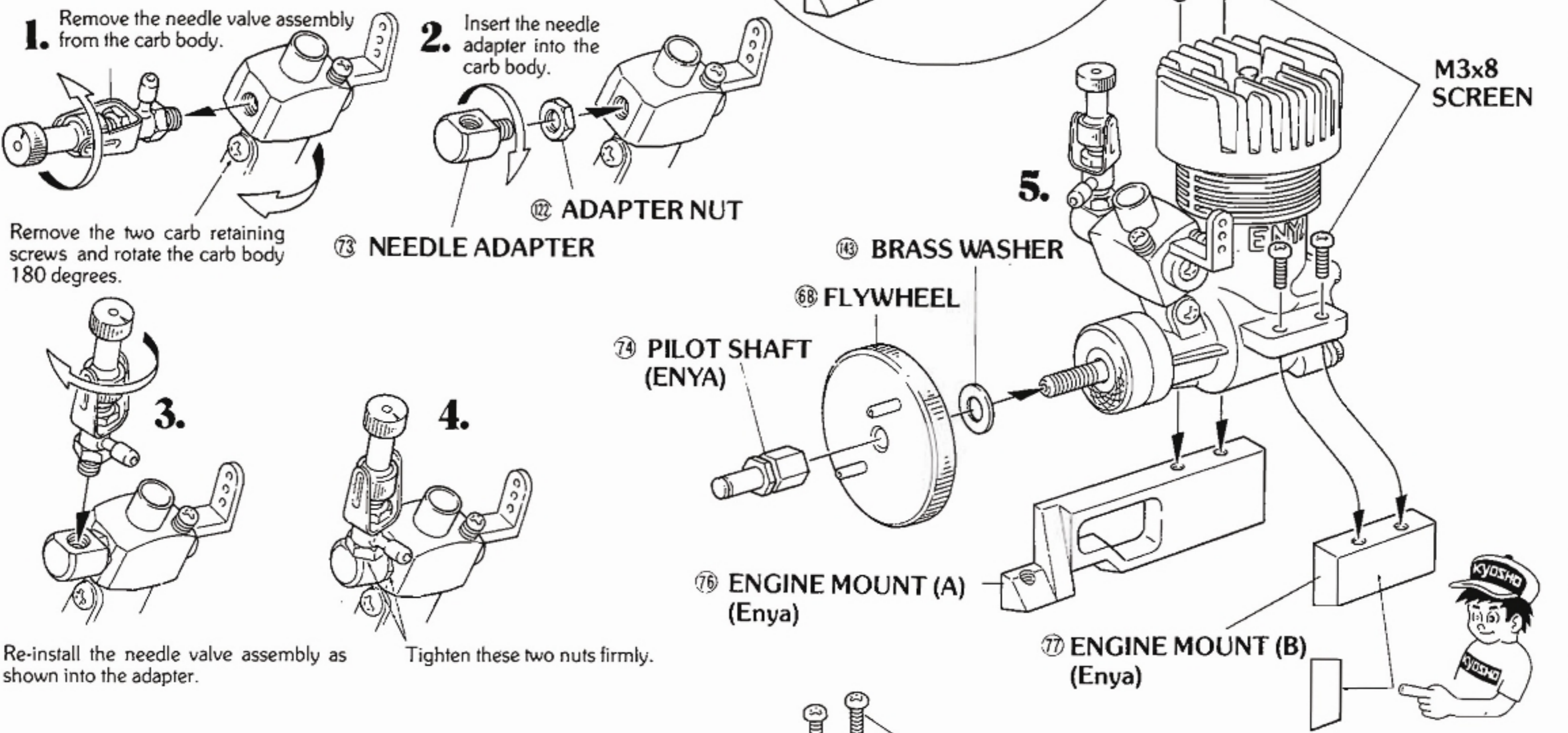

24 INSTALLATION OF ENGINE MOUNT FOR O.S.

- If you are using the OS-CZ1 Engine use the illustration below

Note! If you are using the O.S. .10 FSR-B, place the washer that comes with your engine between the starter gear and the drive washer of the engine. This will provide adequate clearance for the flywheel and starter gear. If you are using a standard O.S. .10 FSR then a #PN-59 Heat Sink will need to be on the cylinder head.

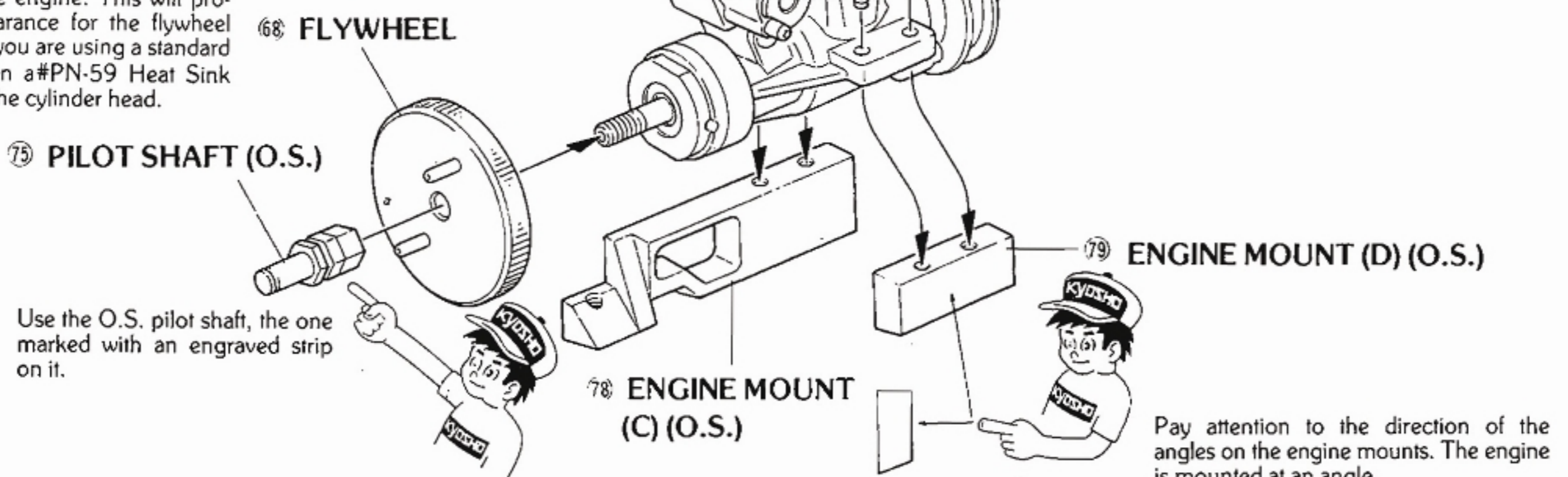

25 INSTALLATION OF MUFFLER

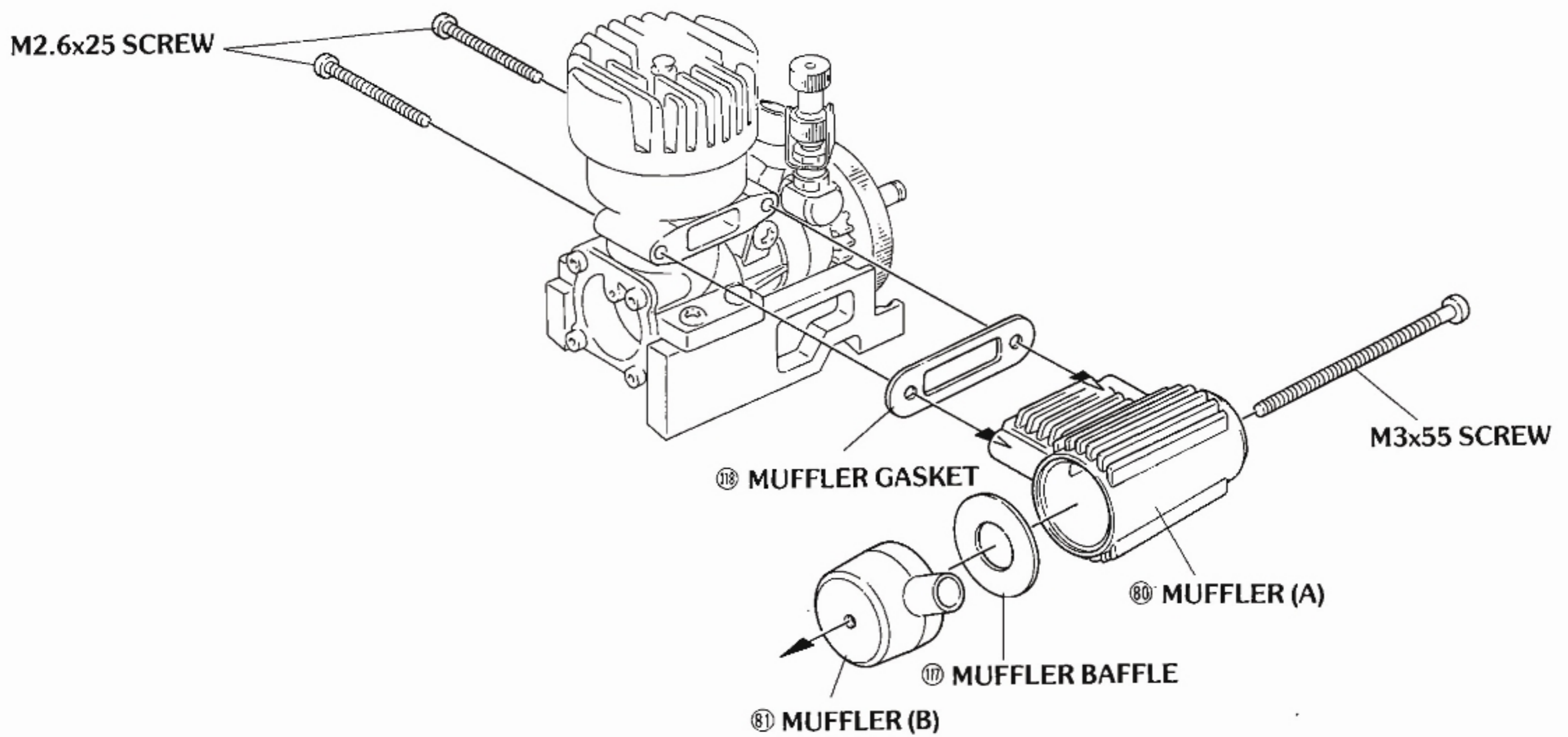

26 INSTALLATION OF CLUTCH

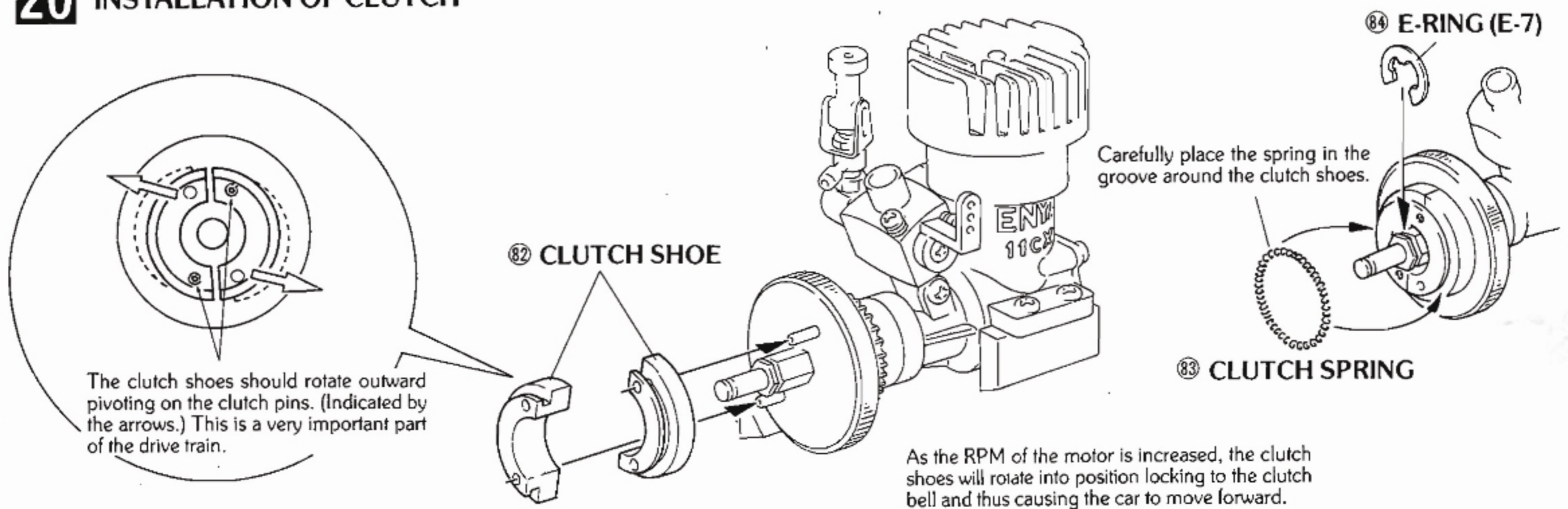

27 INSTALLATION OF CLUTCH BELL AND AIR FILTER

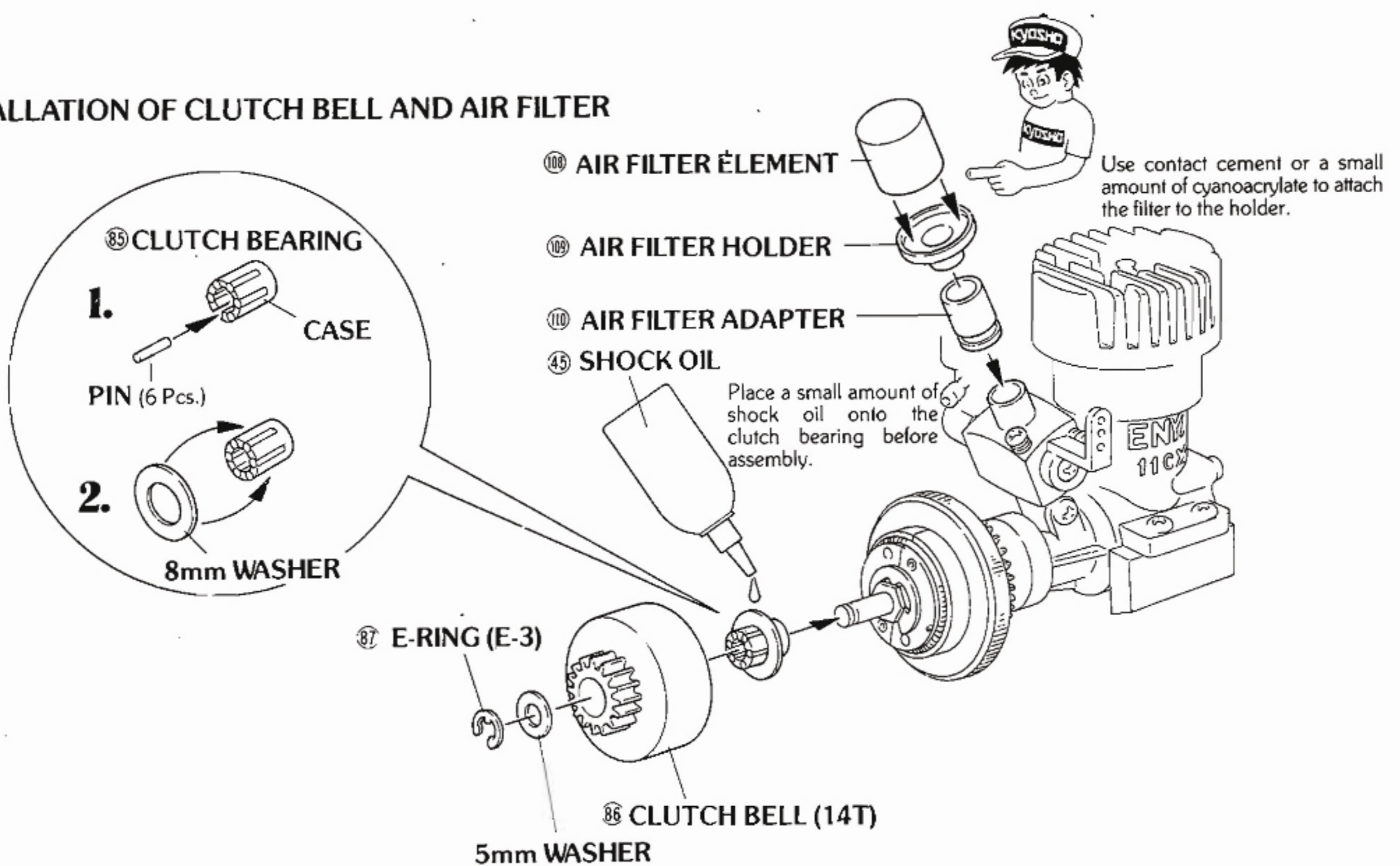

28 MOUNTING OF ENGINE

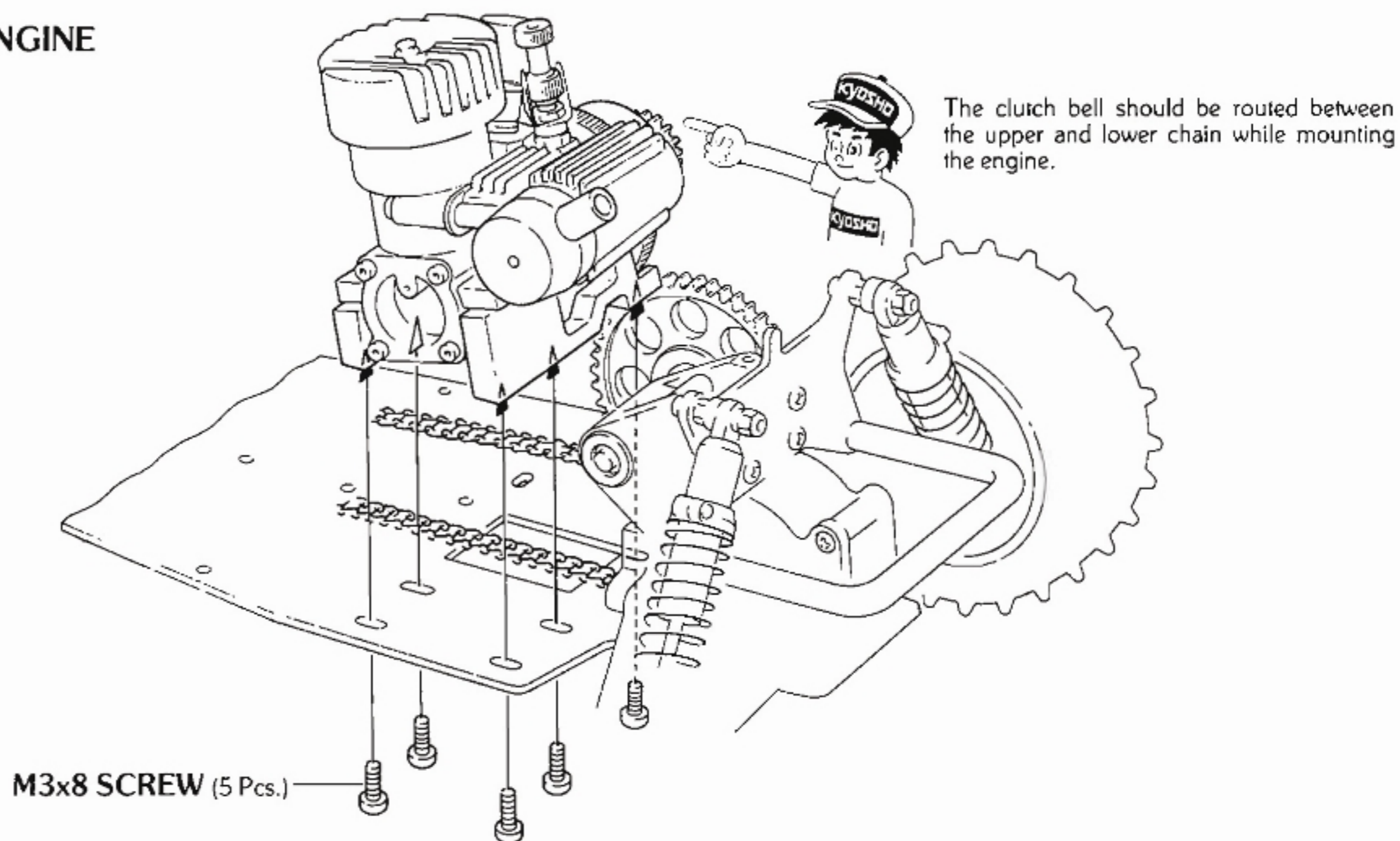

29 INSTALLATION OF CHAIN GUIDE

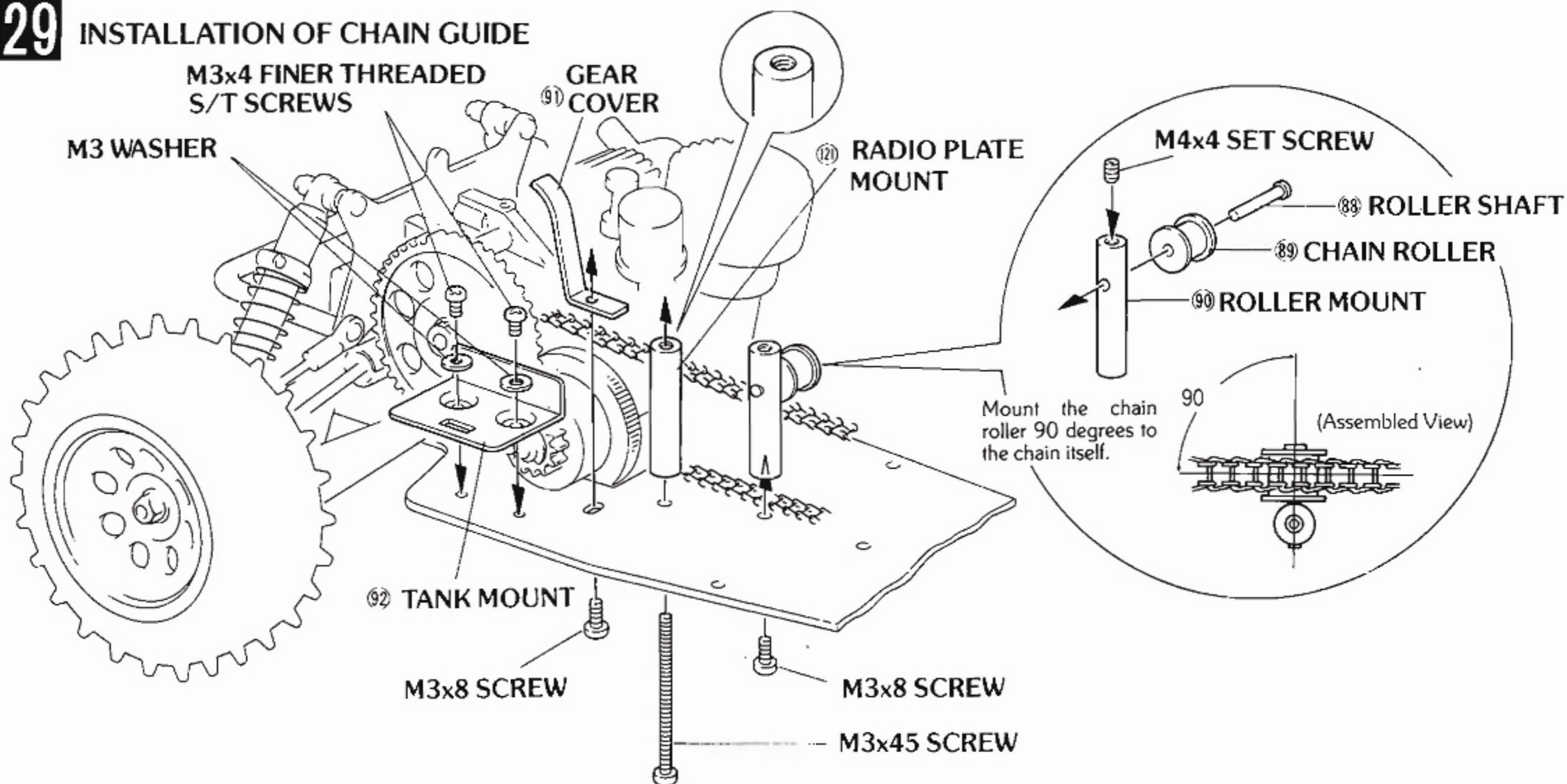

30 HOW TO CHECK YOUR RADIO SYSTEM

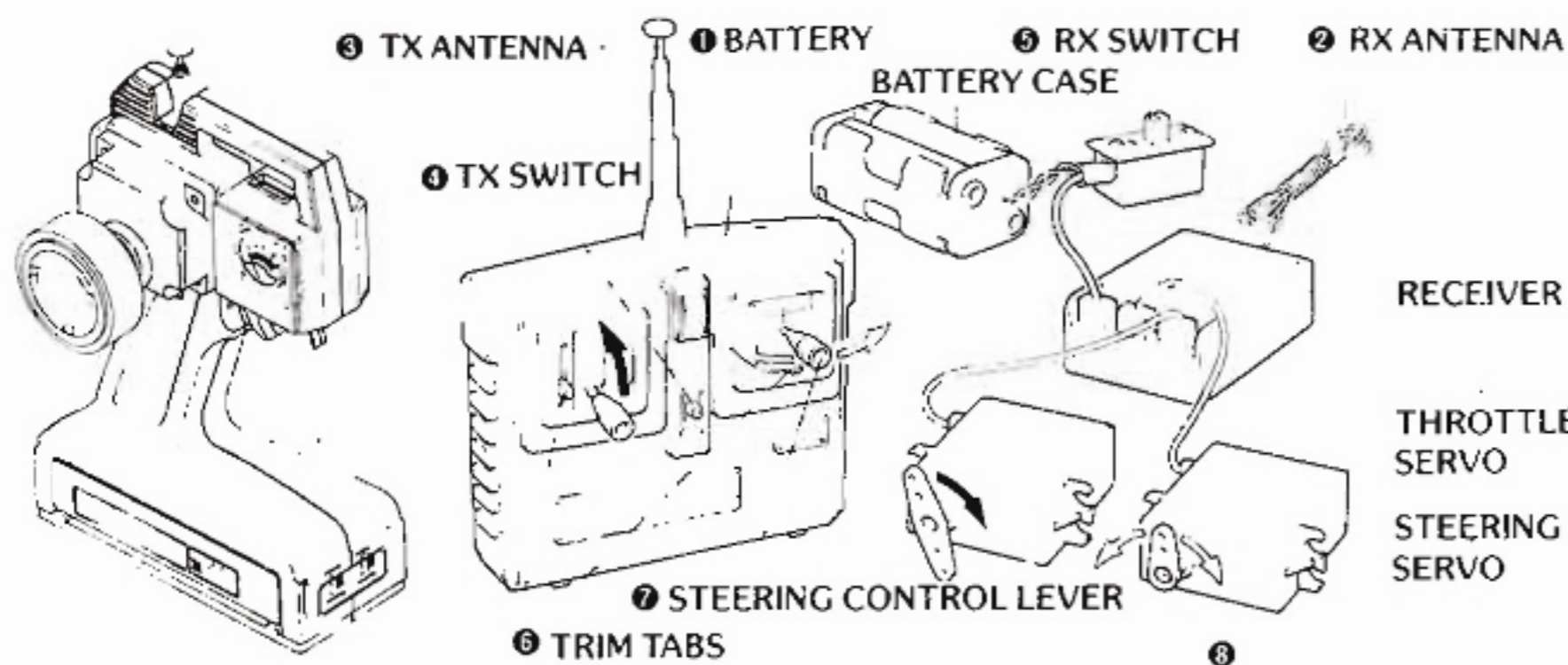

• Follow steps 1-8.

1. Install the batteries into both the transmitter and receiver. If your radio is a rechargeable system, charge it as outlined in the manual that came with your set.
2. Unwind the receiver antenna and plug the servo and battery connectors into the receiver.
3. Extend the transmitter antenna.
4. Turn on the power switch of the transmitter.
5. Turn on the power switch of the receiver.
6. Set the small trim levers to the center position and make sure that both main control sticks are also centered.
7. Move both main control sticks slowly through their full travel. The servo horns should move in proportion to the movement of your sticks.
8. When trim levers and sticks are at their neutral positions, the servo horns should be centered. You may now turn off the receiver, then the transmitter and unplug the servos and battery from the receiver.



*It is important to always switch the transmitter on first . . . then the receiver. When turning off the system, turn off the receiver first and then the transmitter.

31 INSTALLATION OF SERVO

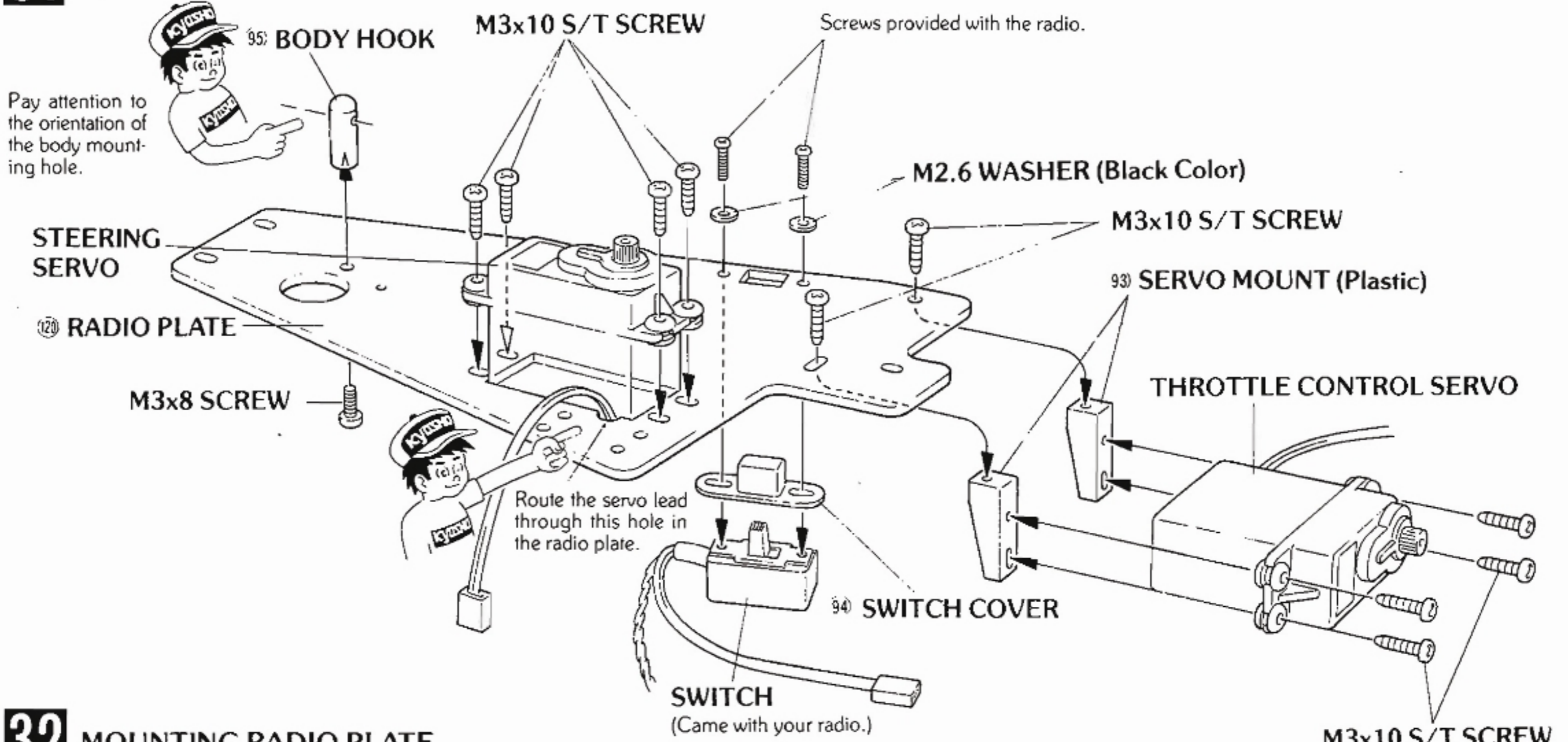

32 MOUNTING RADIO PLATE

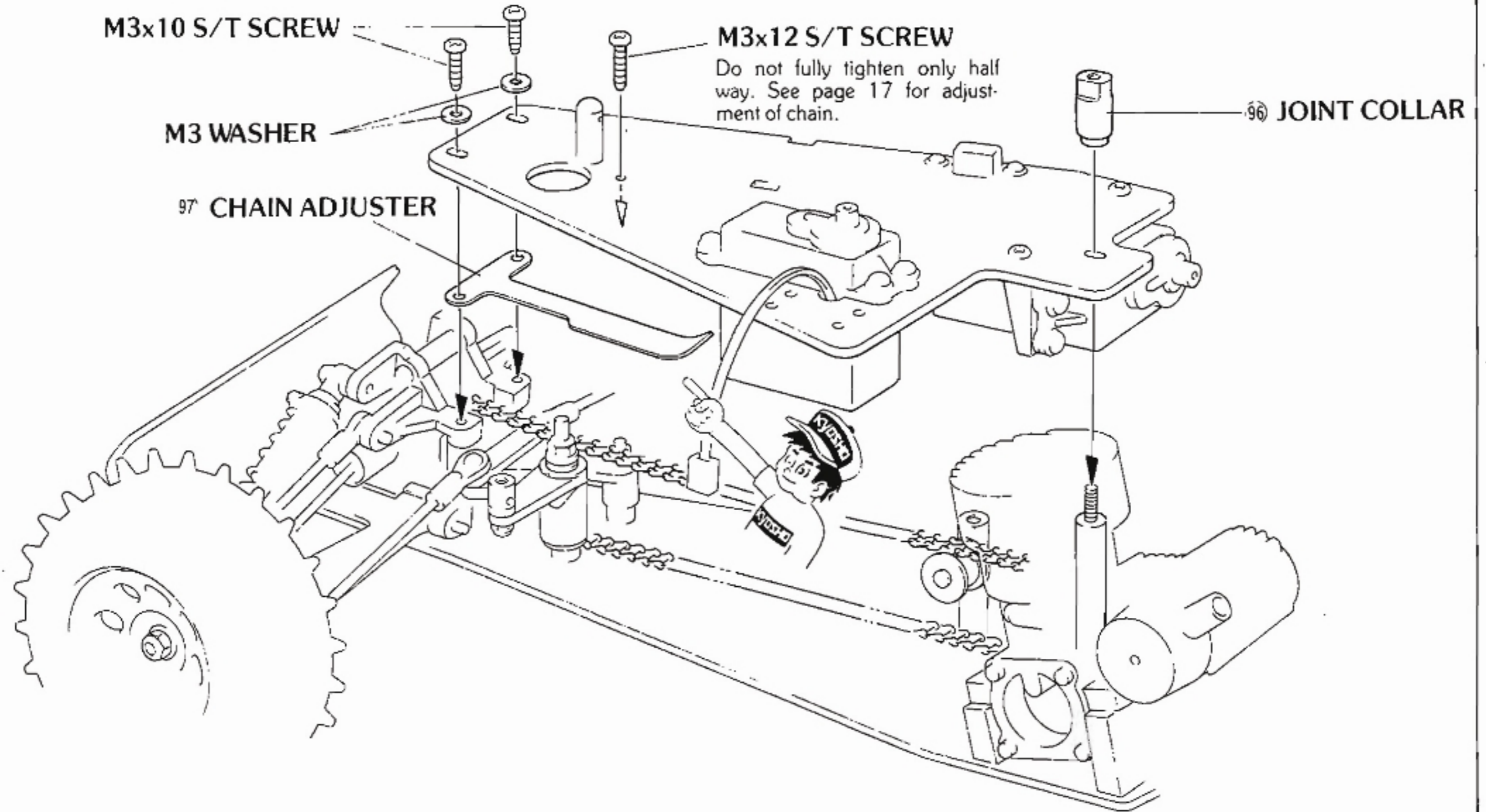

33 STEERING CONTROL LINKAGE

A servo horn with a length of at least 16mm from the center to the hole is necessary. Remove the three unnecessary horn arms from two servo horns as they will not be used. Only one arm is necessary for both horns.

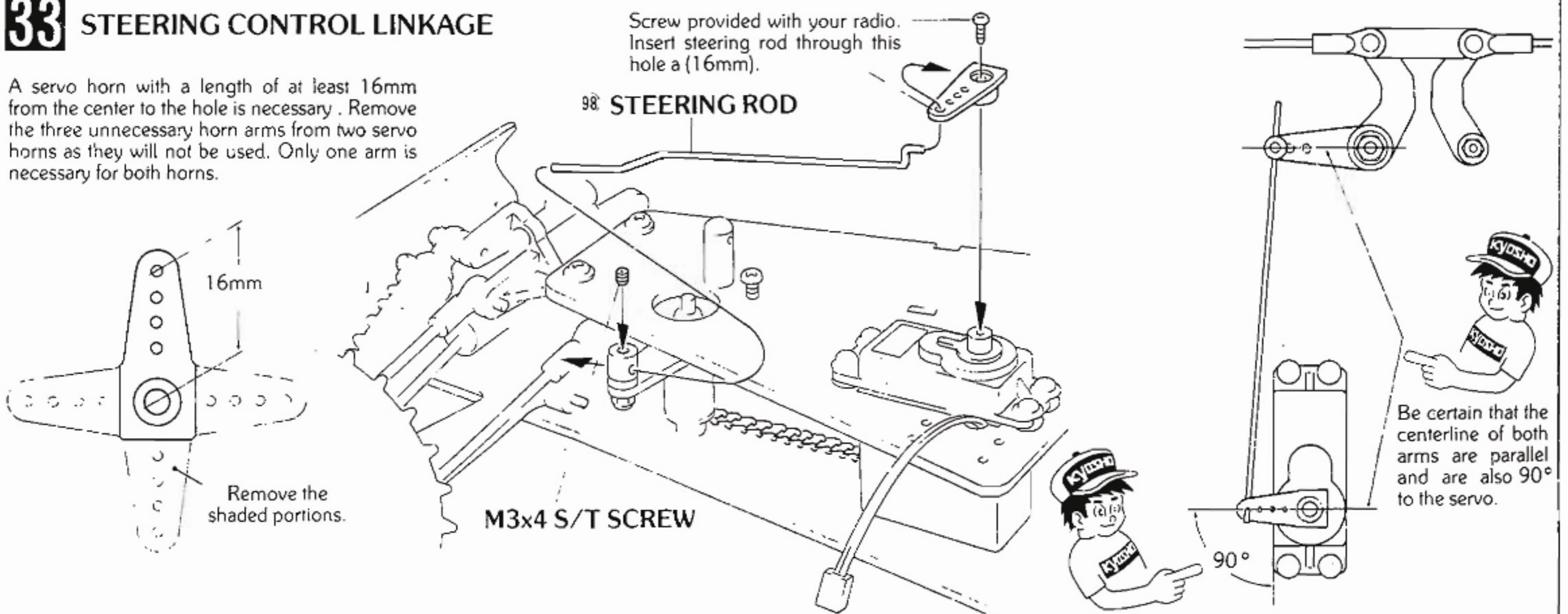

34 THROTTLE CONTROL LINKAGE

• ENYA 11 CX

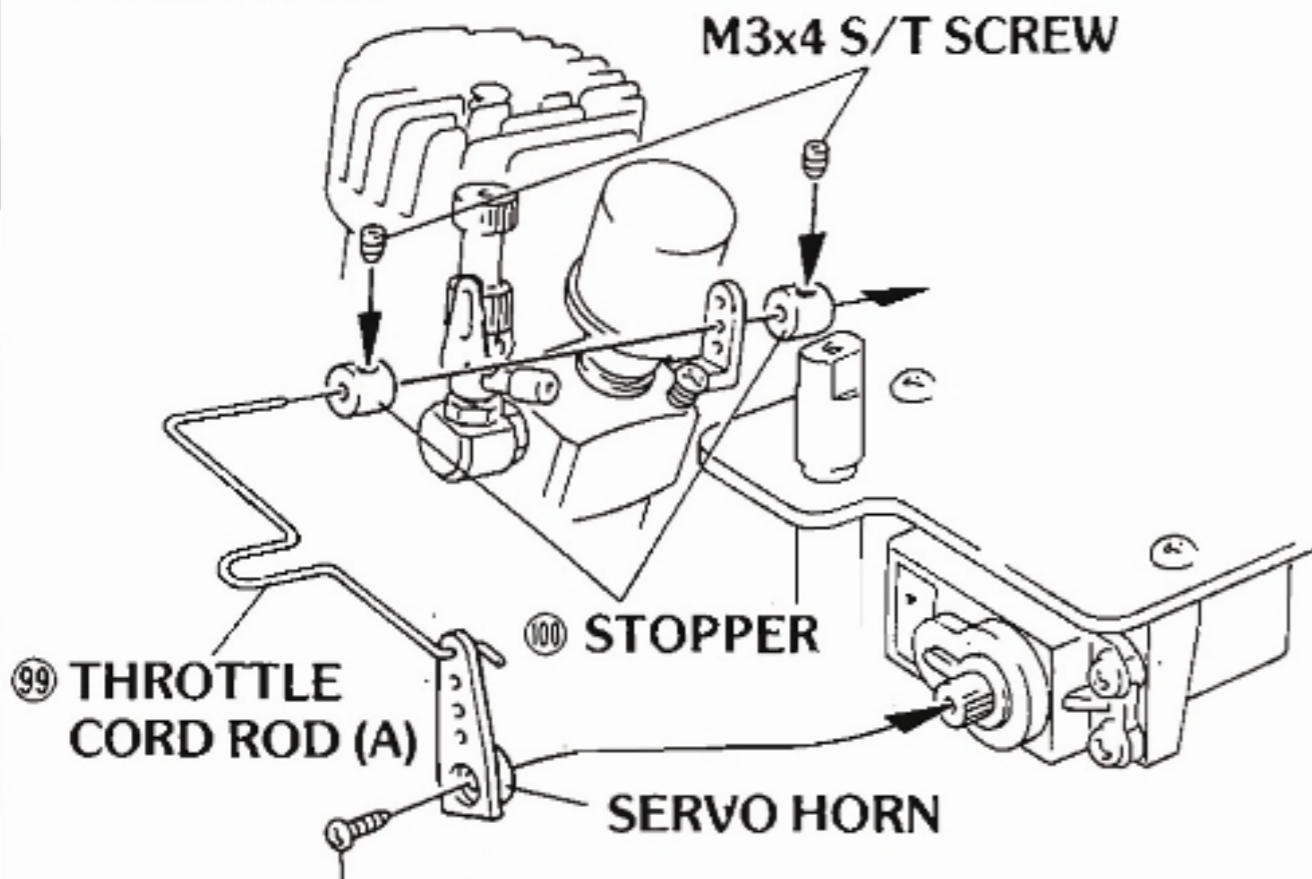

This screw is provided with your radio.

Throttle control stick for the low throttle position. On a pistol grip type transmitter, the "Trigger" is the throttle control lever. When it is pulled in that should be high throttle and when it is released that should be the low throttle position.

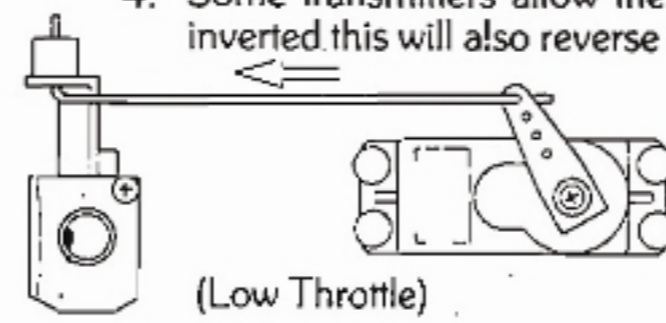
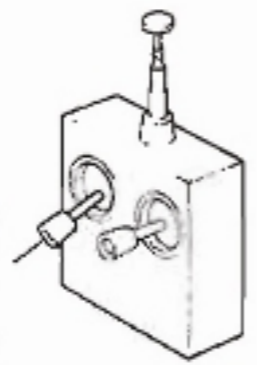

(Low Throttle)

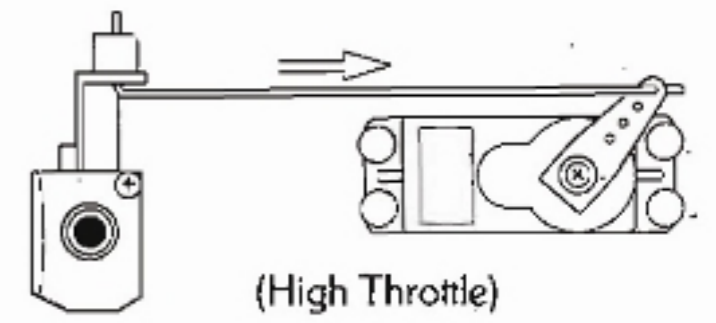

(High Throttle)

• ENYA-09
• O.S. CZ-1

ENYA-09VIBB

Note! The shaded area may need to be bent straight up or to the other side to allow for clearance past the main gear. This will depend on the engine/carb being used.

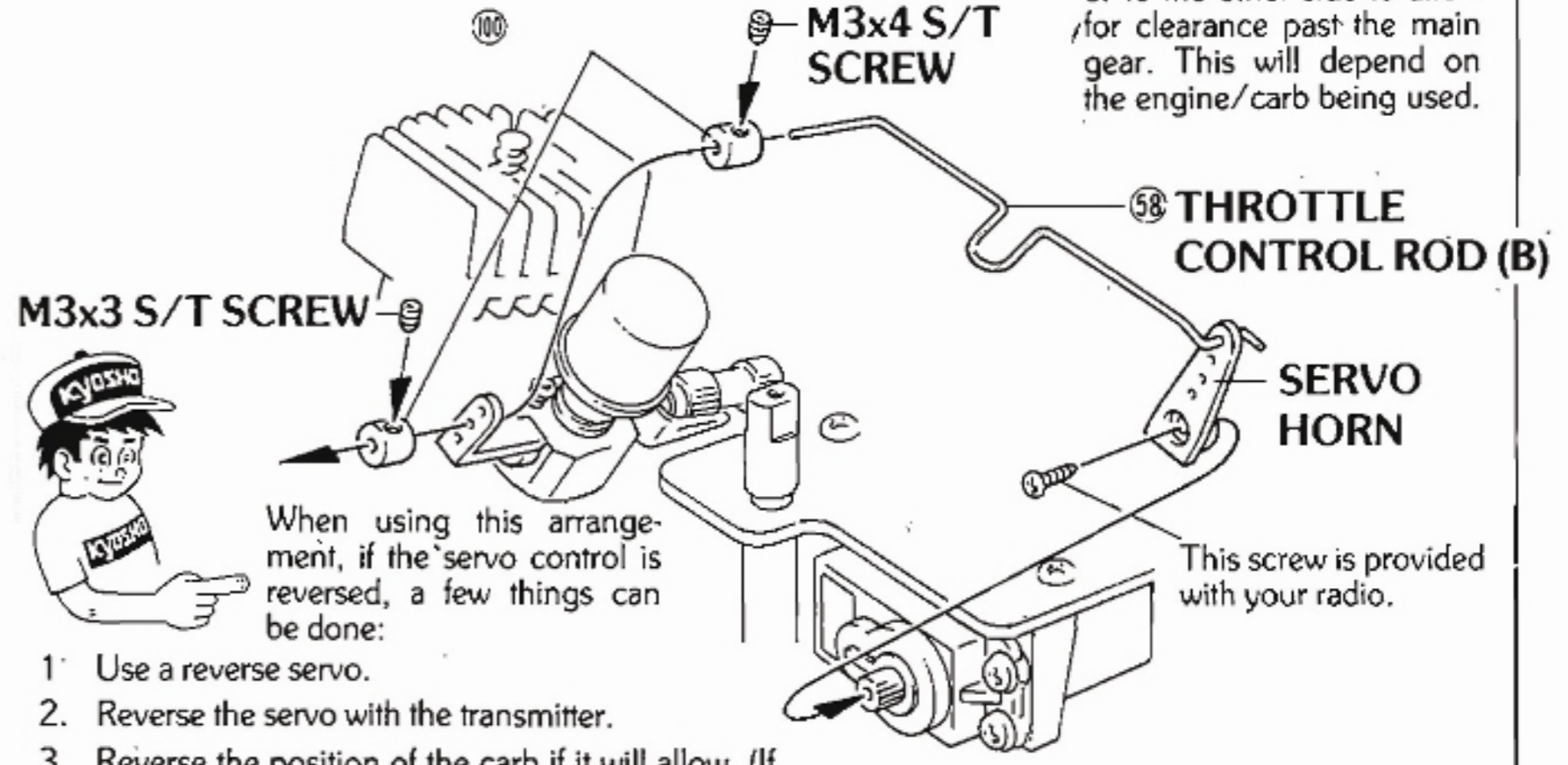

M3x3 S/T SCREW



When using this arrangement, if the servo control is reversed, a few things can be done:

1. Use a reverse servo.
2. Reverse the servo with the transmitter.
3. Reverse the position of the carb if it will allow. (If this is done the control rod may need to be modified.)
4. Some transmitters allow the throttle lever to be inverted this will also reverse the rotation.

This screw is provided with your radio.

35 INSTALLATION OF FUEL TANK

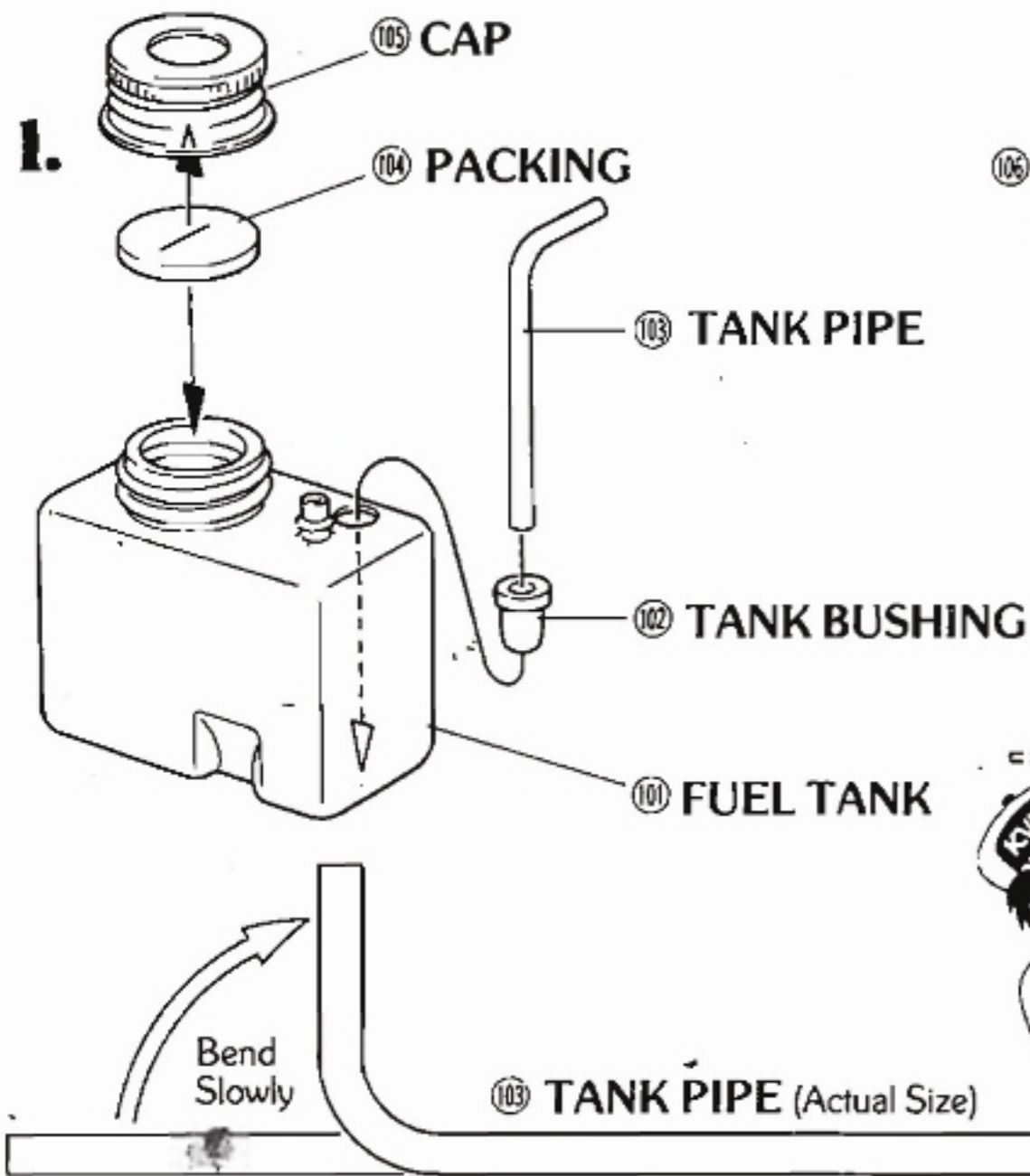

Carefully bend the tank pipe as shown using the illustration above as a guide.

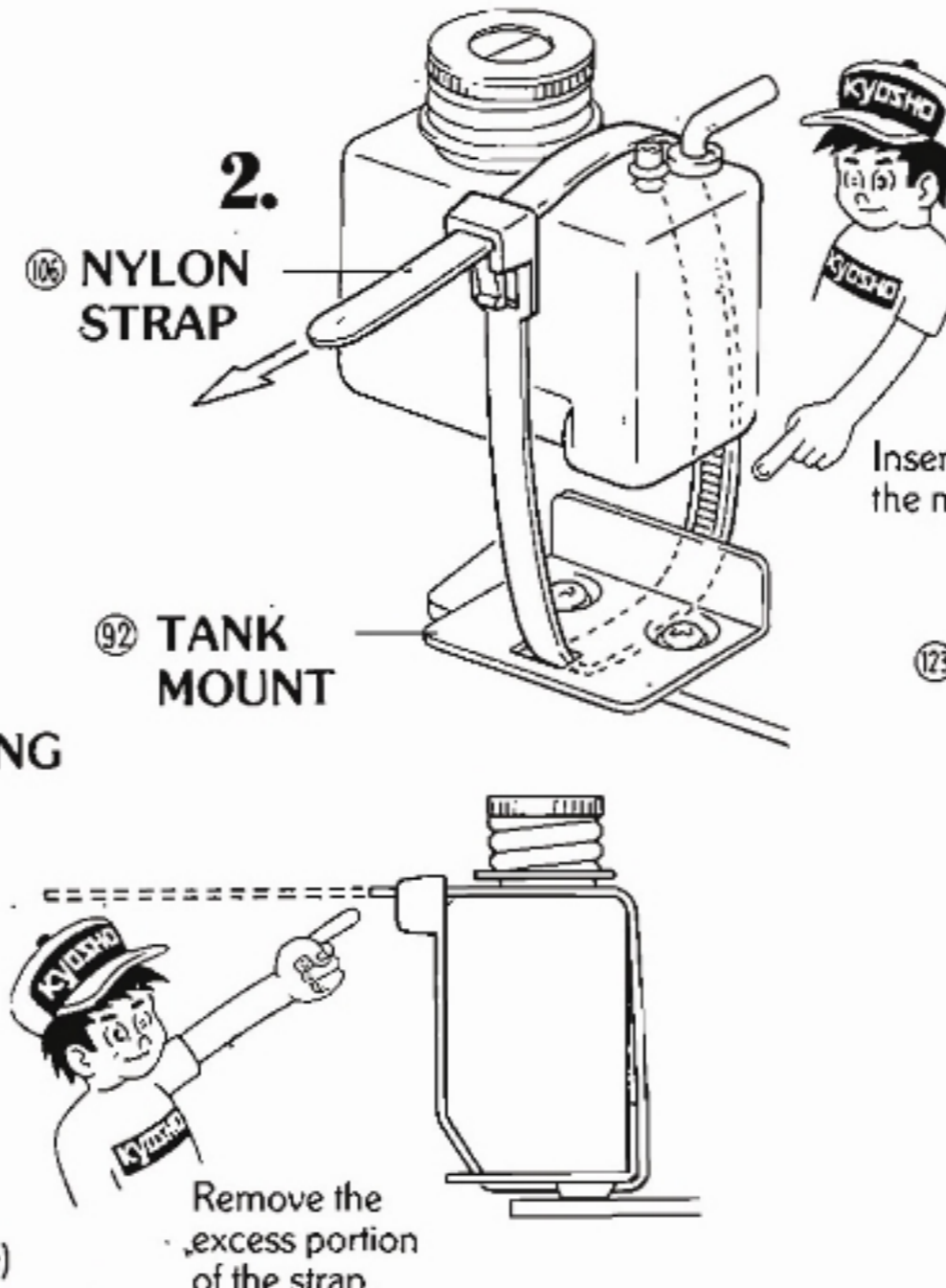

Note! It may be easier to install the strap if you remove the tank mount beforehand

123 Cut the tubing to length using the illustration below as a guide.

Insert the other end into the hole in the muffler.

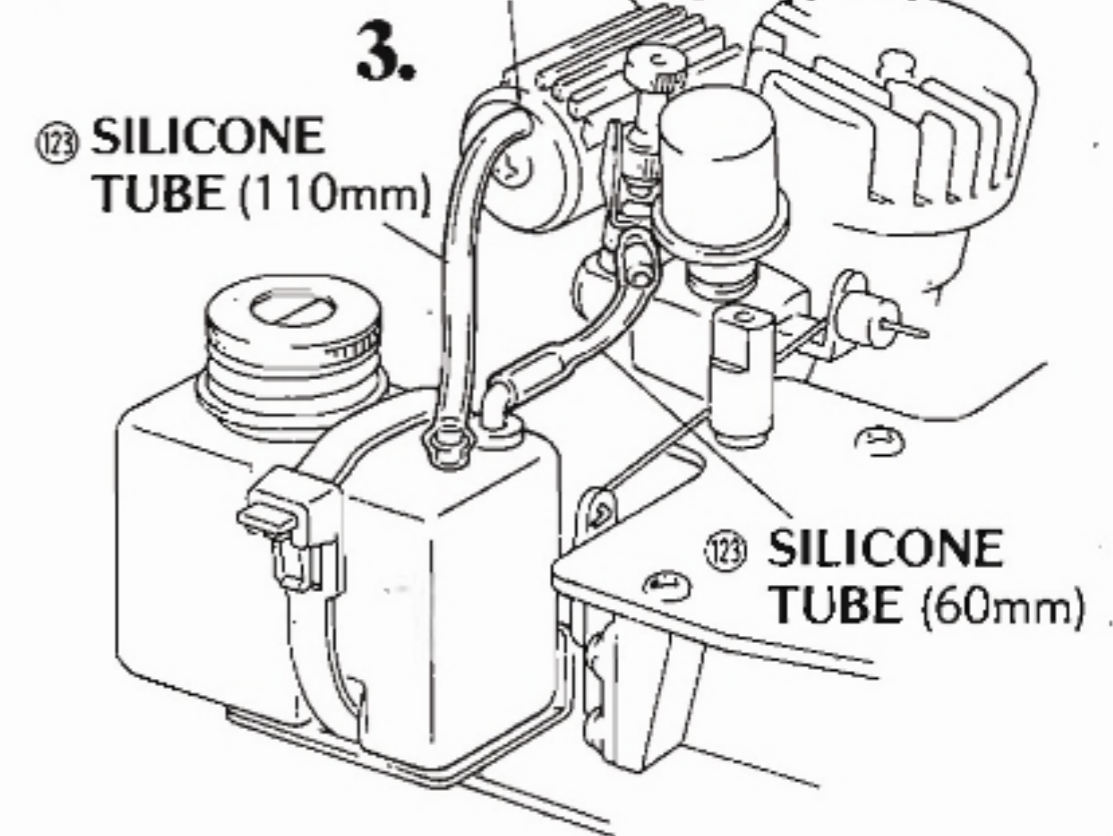

36 INSTALLATION OF JOINT PLATE

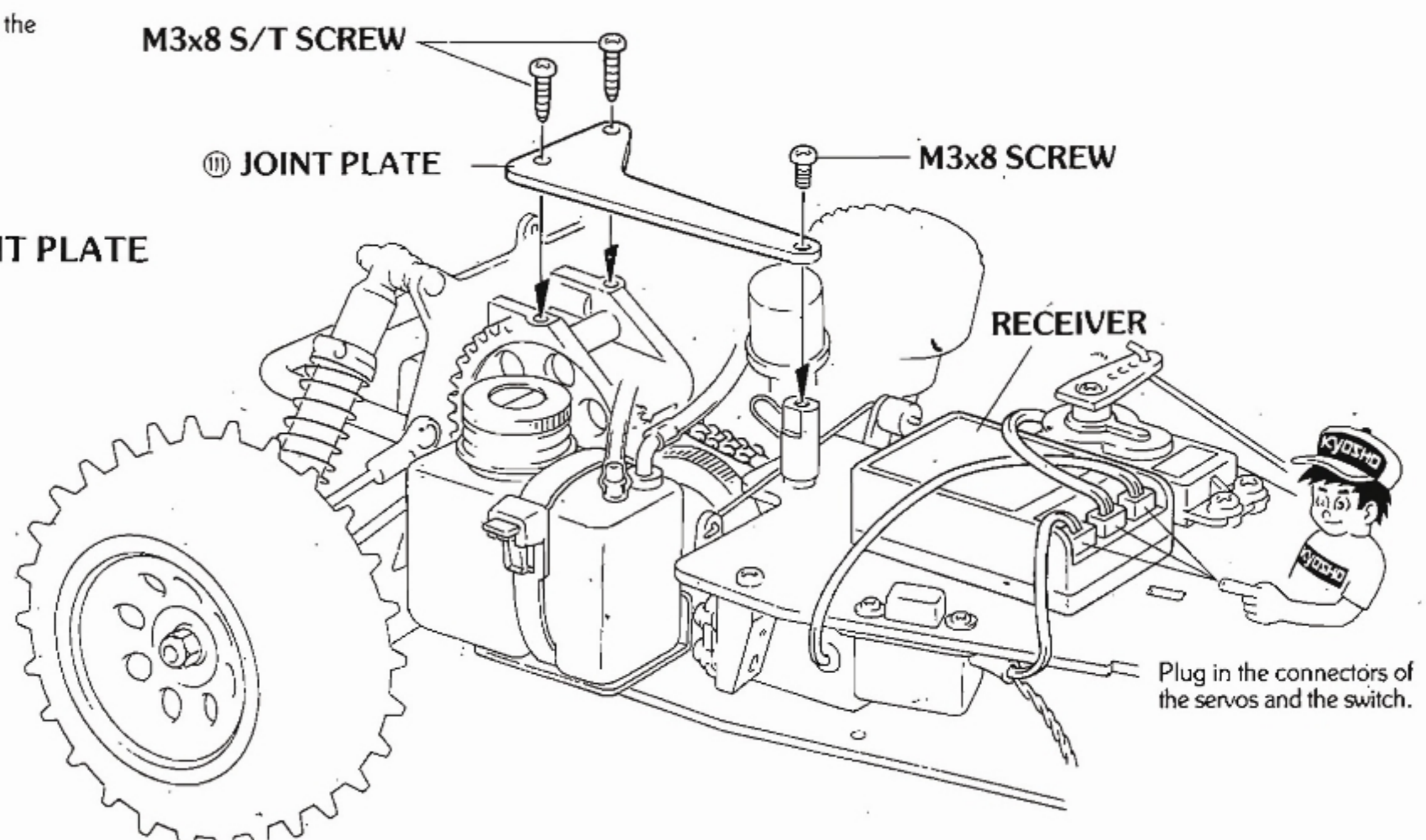

M3x8 S/T SCREW

111 JOINT PLATE

M3x8 SCREW

RECEIVER

Plug in the connectors of the servos and the switch.

37 INSTALLATION OF RECEIVER COVER & SIDE COVER

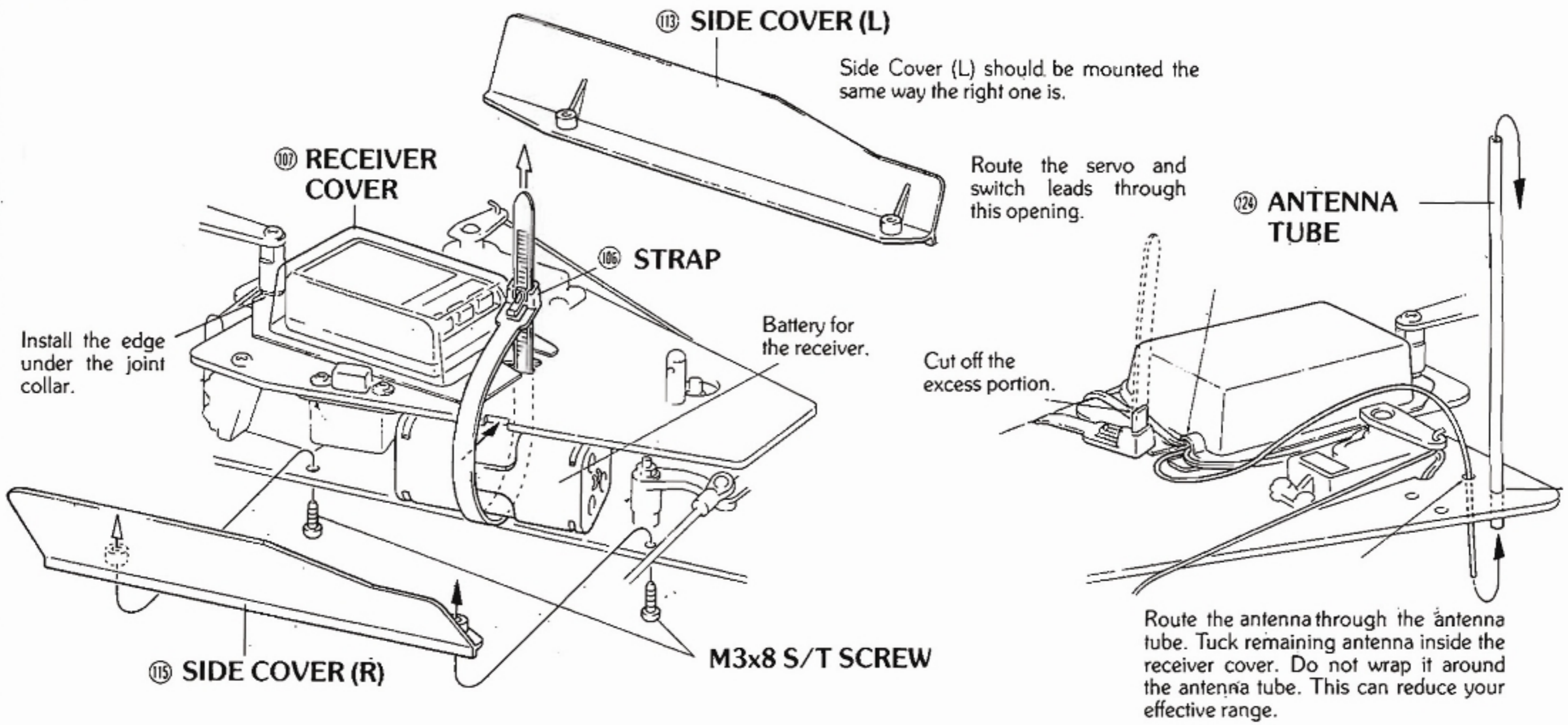

38 CUTTING OUT BODY

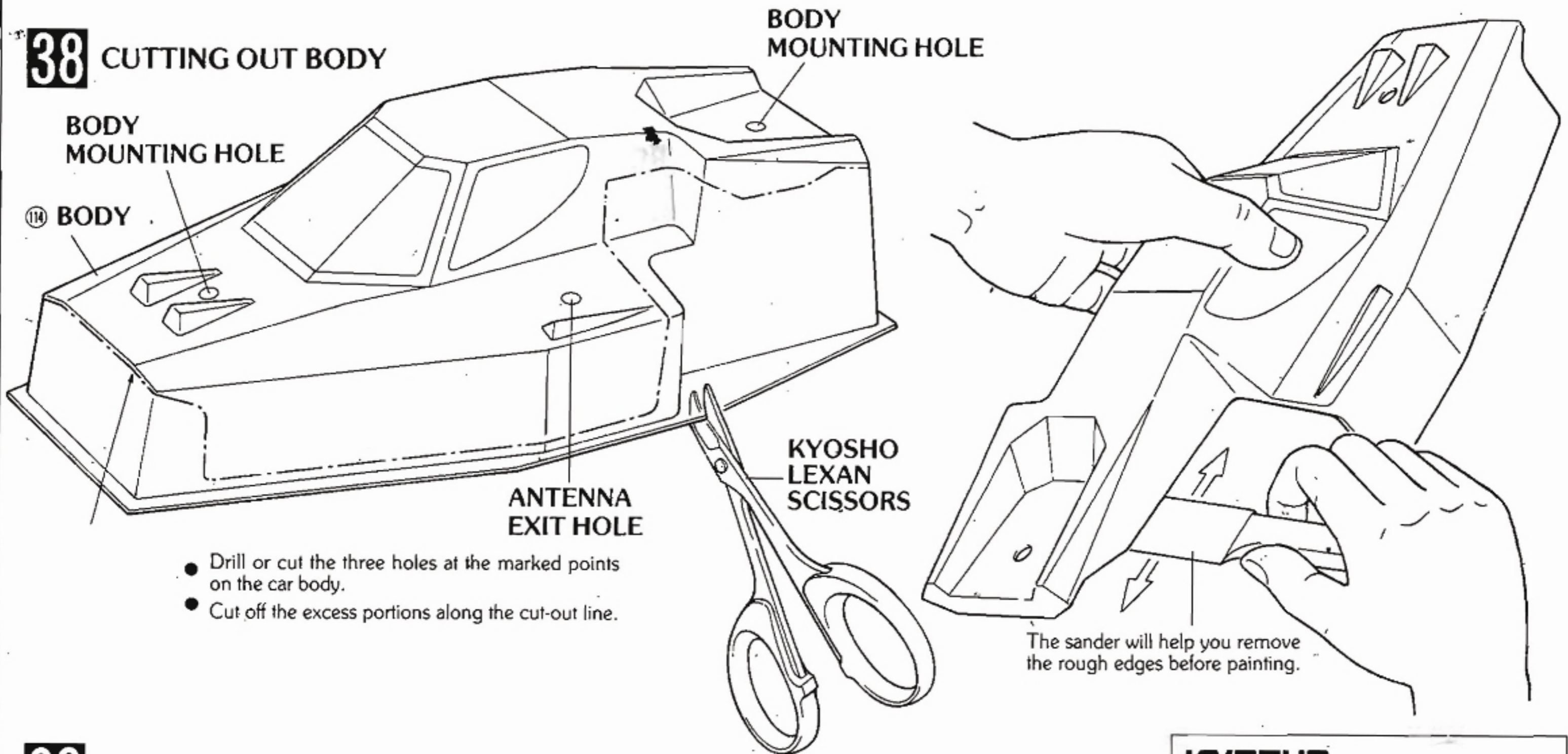

39 PAINTING

First, wash the body to remove any oil or dirt. Rinse thoroughly. Paint the **inside** of the body. You can obtain a color scheme by masking a portion with tape then removing the tape and painting. Apply the lightest color last.

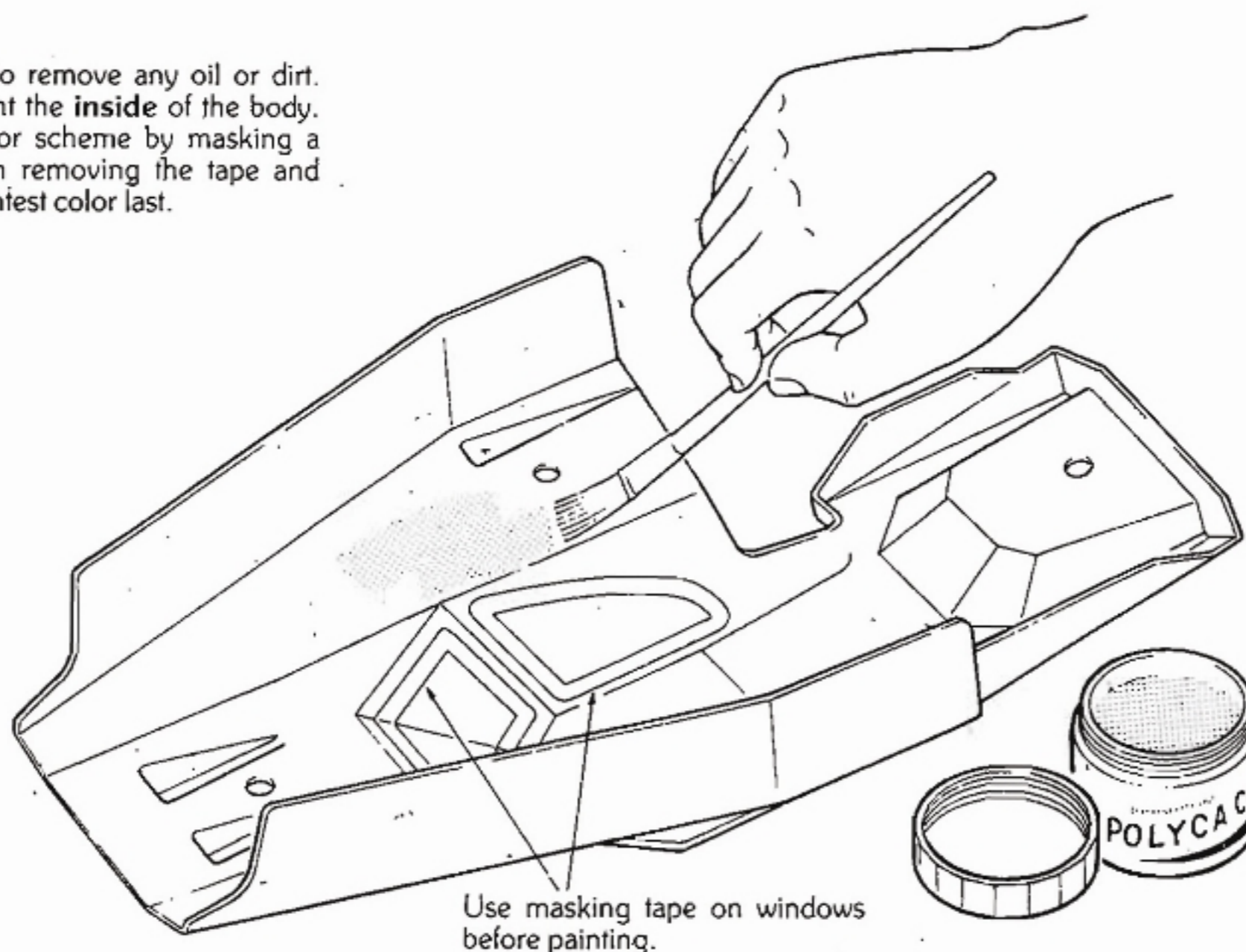

KYOSHO

These special *Lexan Scissors* make trimming bodies a breeze and the sander comes in handy for finishing the rough edges.

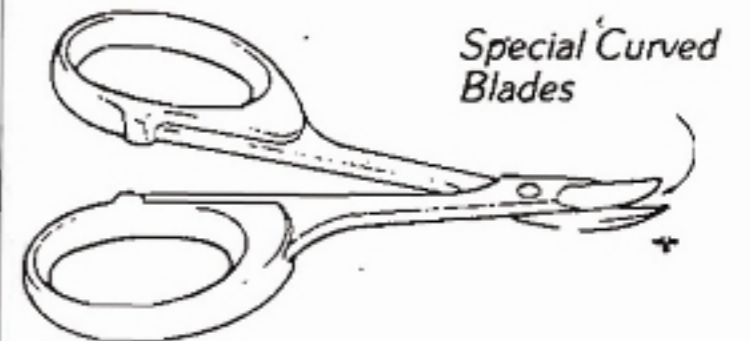

No. 1829

KYOSHO

Polyca Color Paint is available for painting your Lexan bodies. 12 great looking colors.

No. 2230

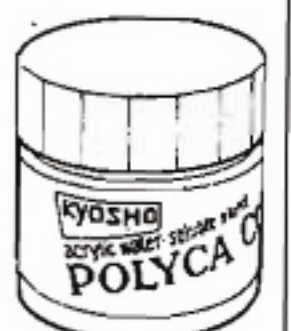

40 MOUNTING OF BODY

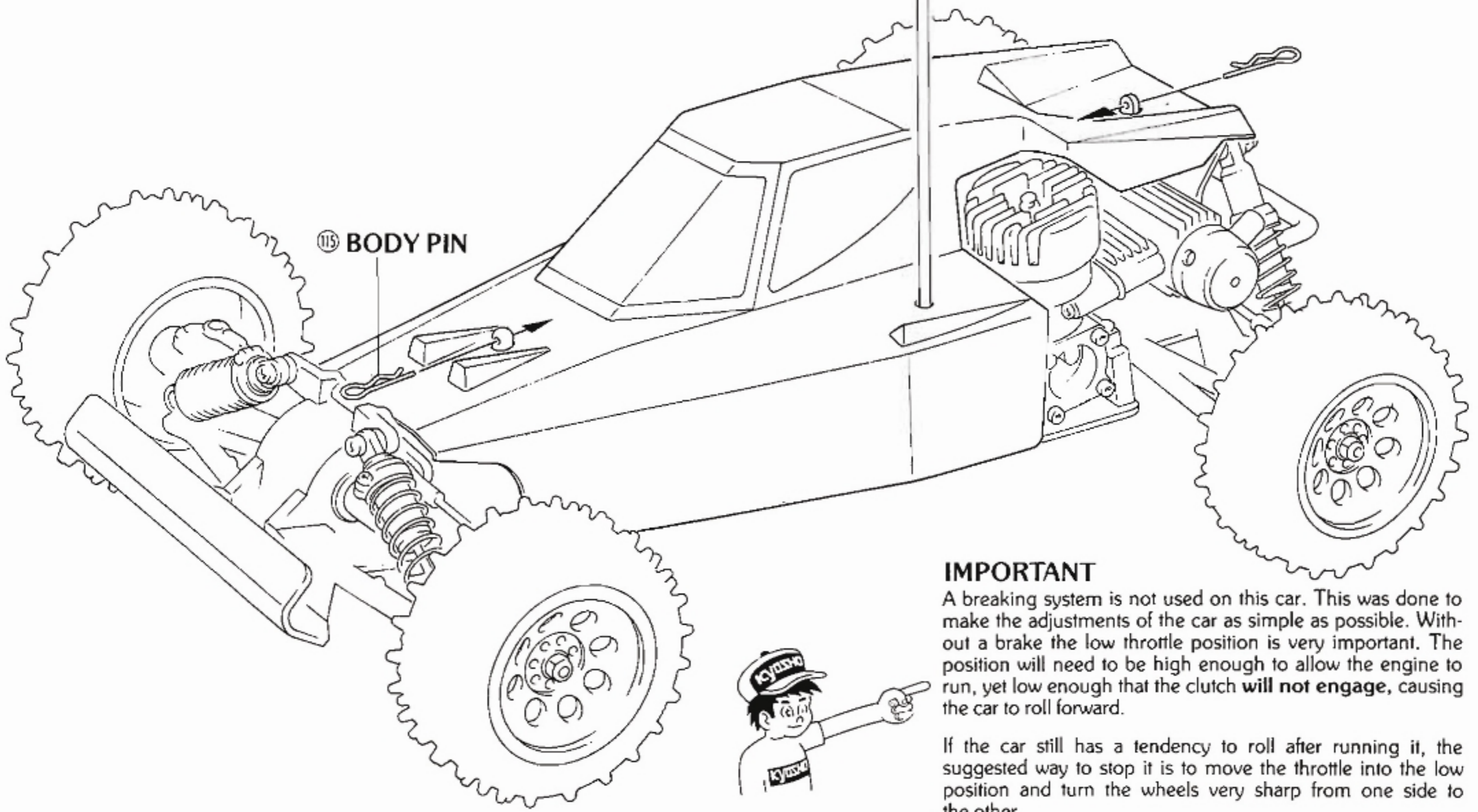

IMPORTANT

A braking system is not used on this car. This was done to make the adjustments of the car as simple as possible. Without a brake the low throttle position is very important. The position will need to be high enough to allow the engine to run, yet low enough that the clutch **will not engage**, causing the car to roll forward.

If the car still has a tendency to roll after running it, the suggested way to stop it is to move the throttle into the low position and turn the wheels very sharp from one side to the other.

EXPLODED VIEW OF FRONT AND REAR SHOCKS

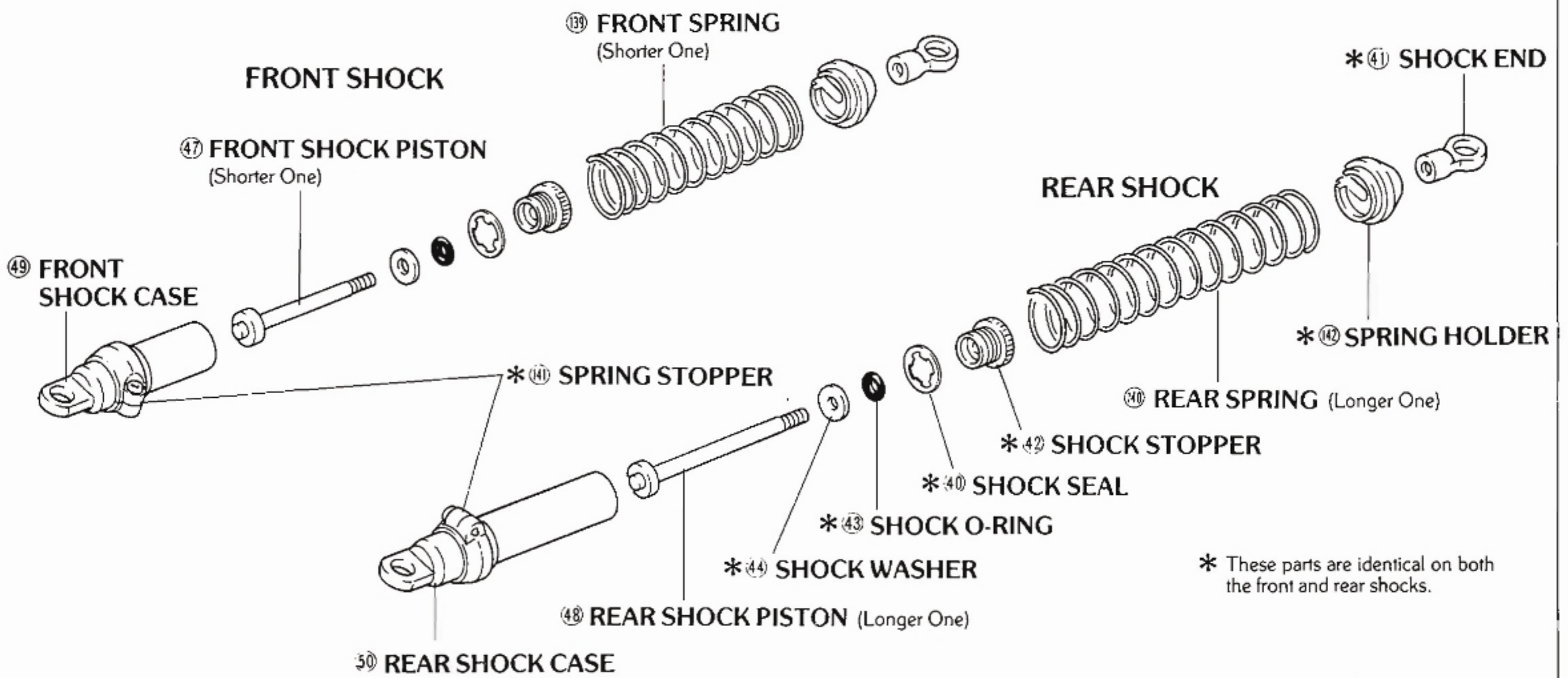

EXPLODED VIEW OF DIFFERENTIALS

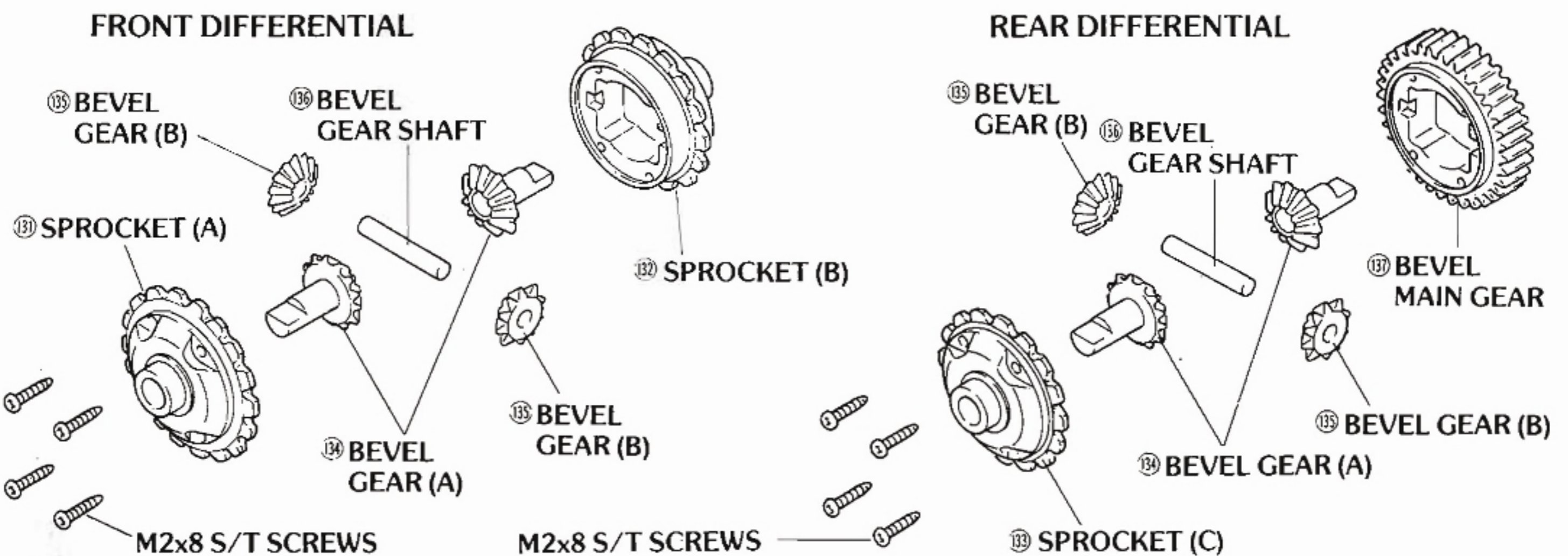

ADJUSTMENT OF DRIVE CHAIN

After the car has been run for a while the drive chain has a tendency to stretch. In order to keep the chain at the proper tension all the time you will need to tighten the adjusting screw M3x12 S/T which has been installed on page 13. If the (M3x12) is too short replace it with a (M3x18 S/T.) After extended use one or even two links of the chain may need to be removed to produce the proper chain tension.

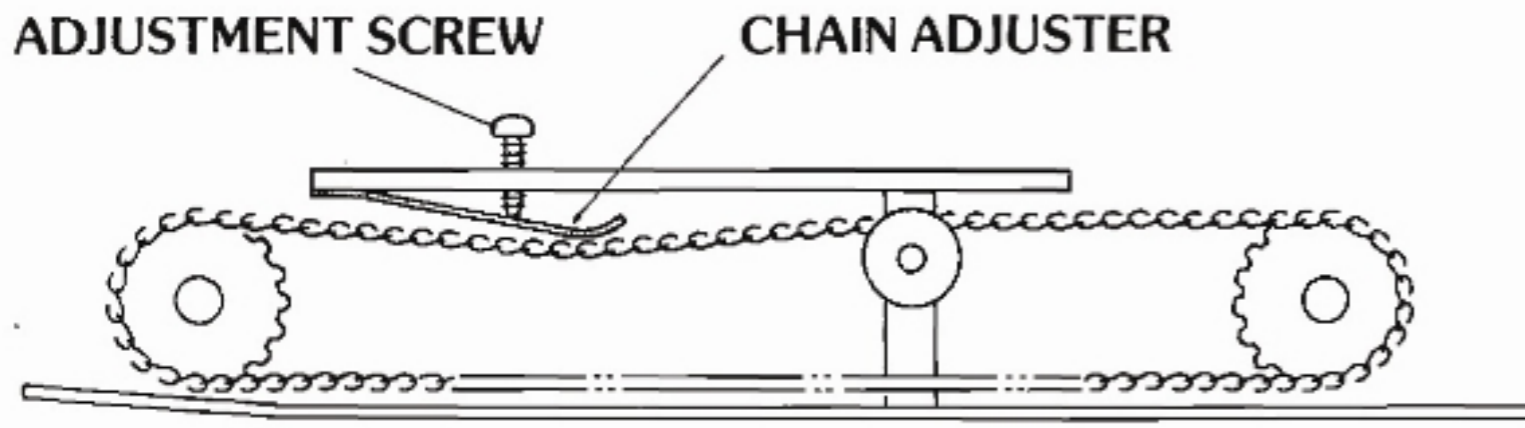

STARTING THE ENGINE

- 1 Fill the fuel tank using a fuel bulb.

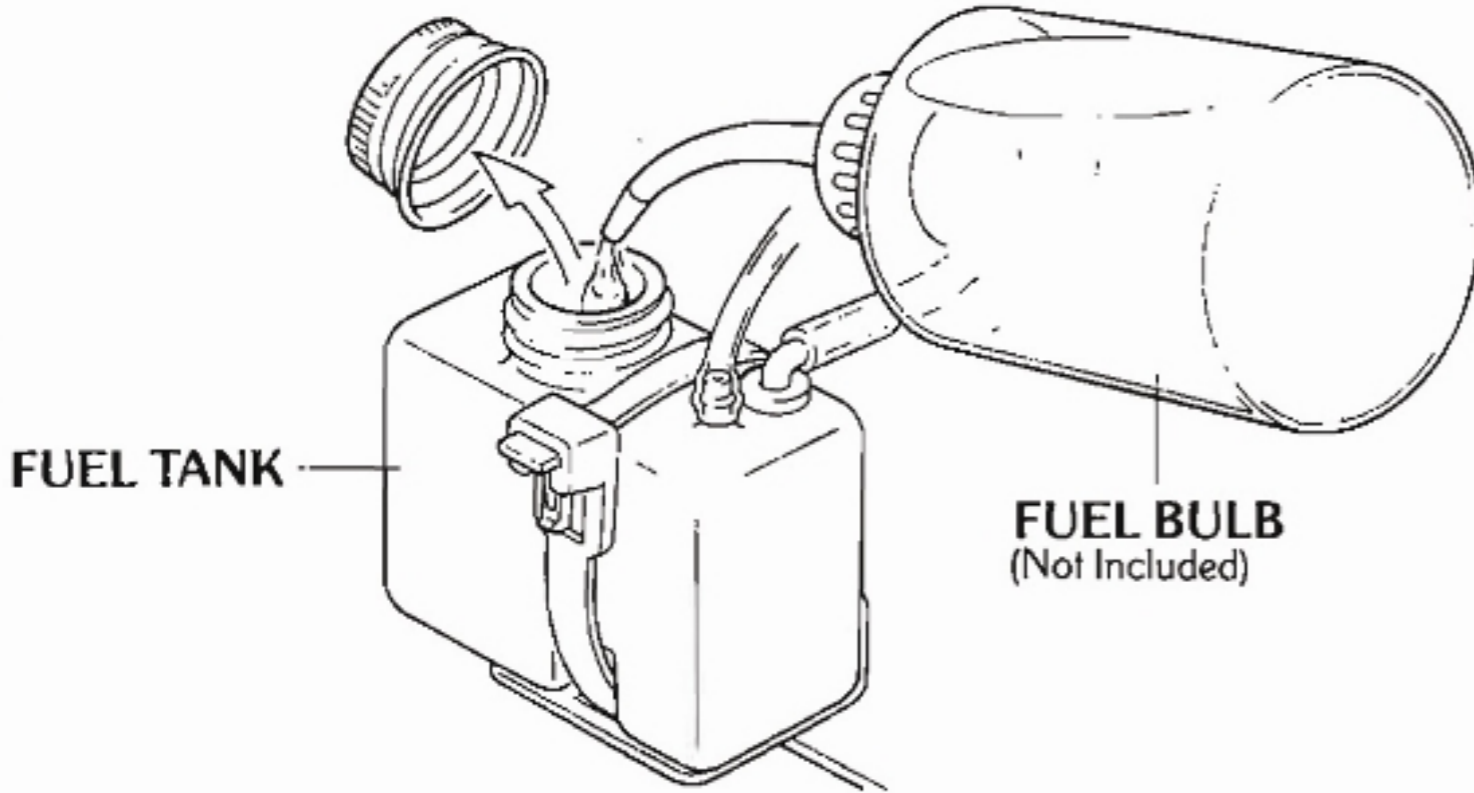

- 2 Remove the glow plug from the head of the engine. Then connect the battery clip to the plug to see if the coil is bright red or not. If it is red reinstall it into the engine. If it does not glow red check the wiring and battery if they are okay then replace the glow plug.

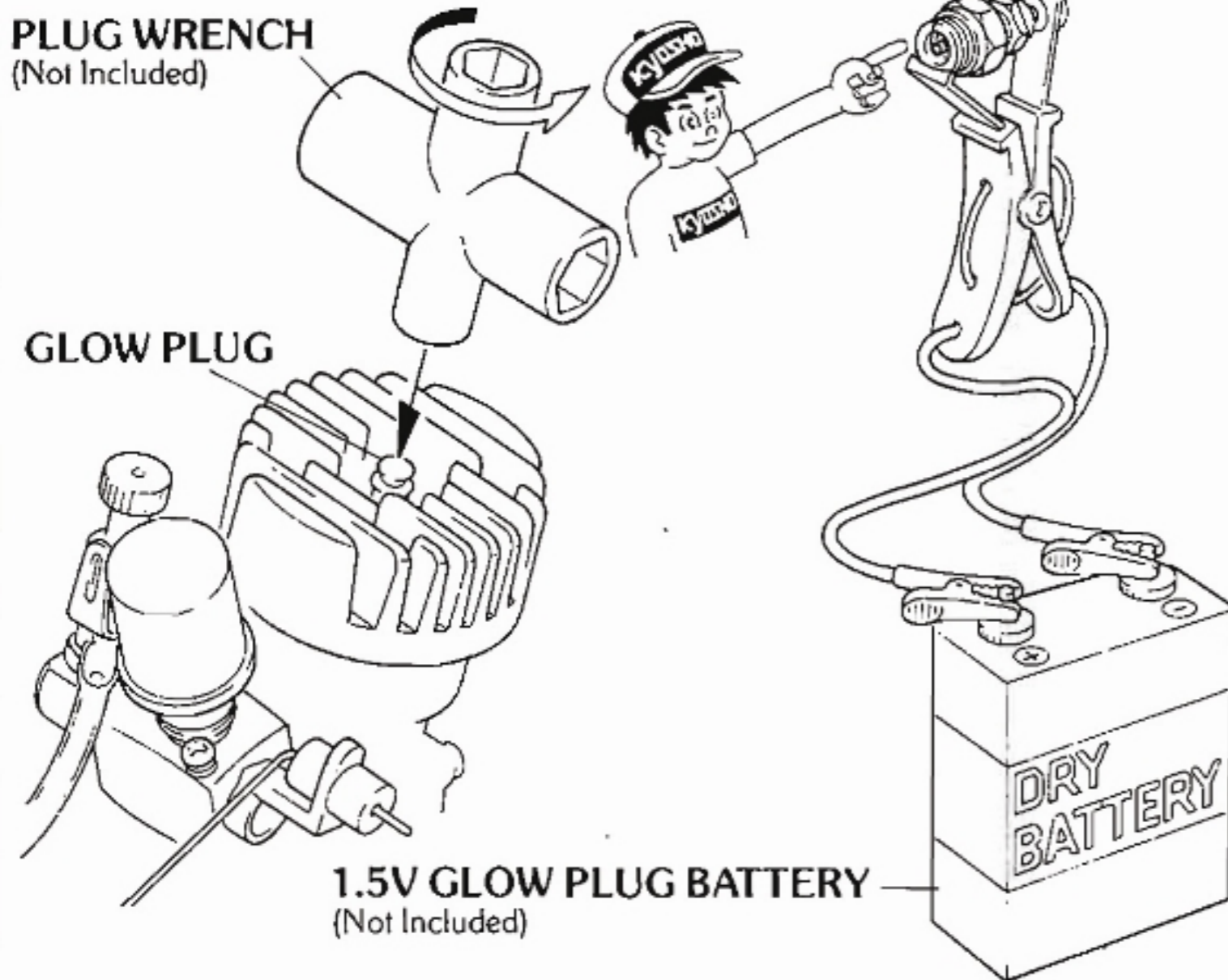

- 3 Place a small amount (2 to 3 drops) of fuel into the air filter element this will prime the engine and will also help trap small particles of dirt and sand.

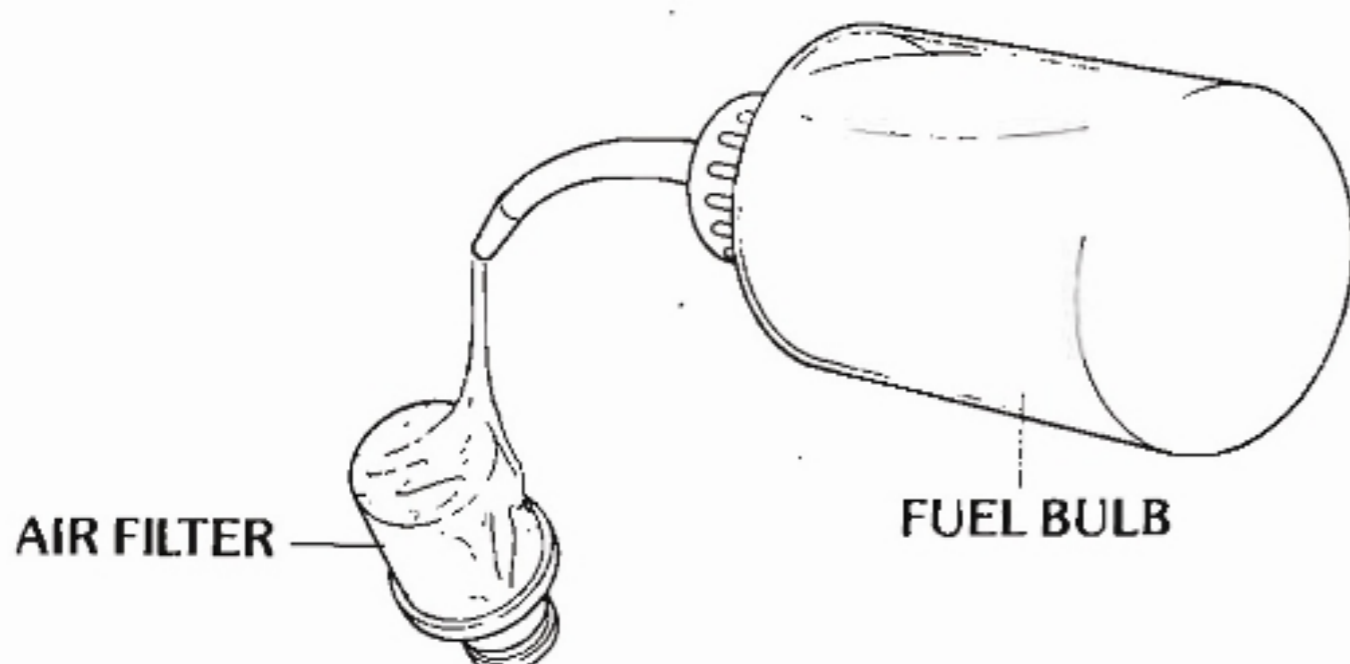

- 4 A few drops of fuel placed directly into the carb is very helpful in starting these type of glow engines.

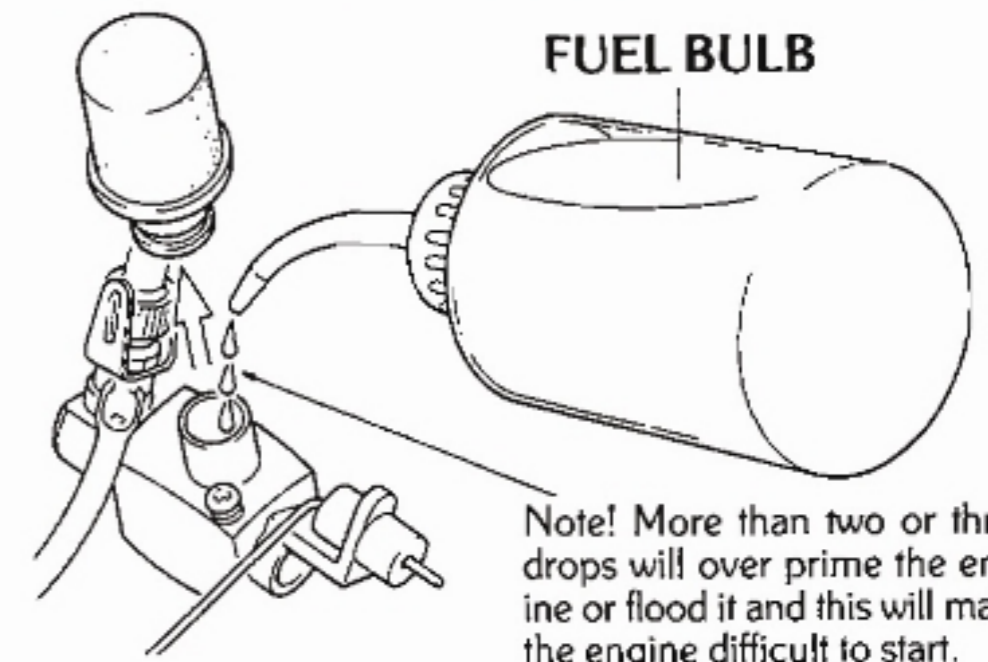

Note! More than two or three drops will over prime the engine or flood it and this will make the engine difficult to start.

- 5 Refer to the engine instruction manual for the correct procedure of adjustment of the carb.

NEEDLE VALVE ADJUSTMENT

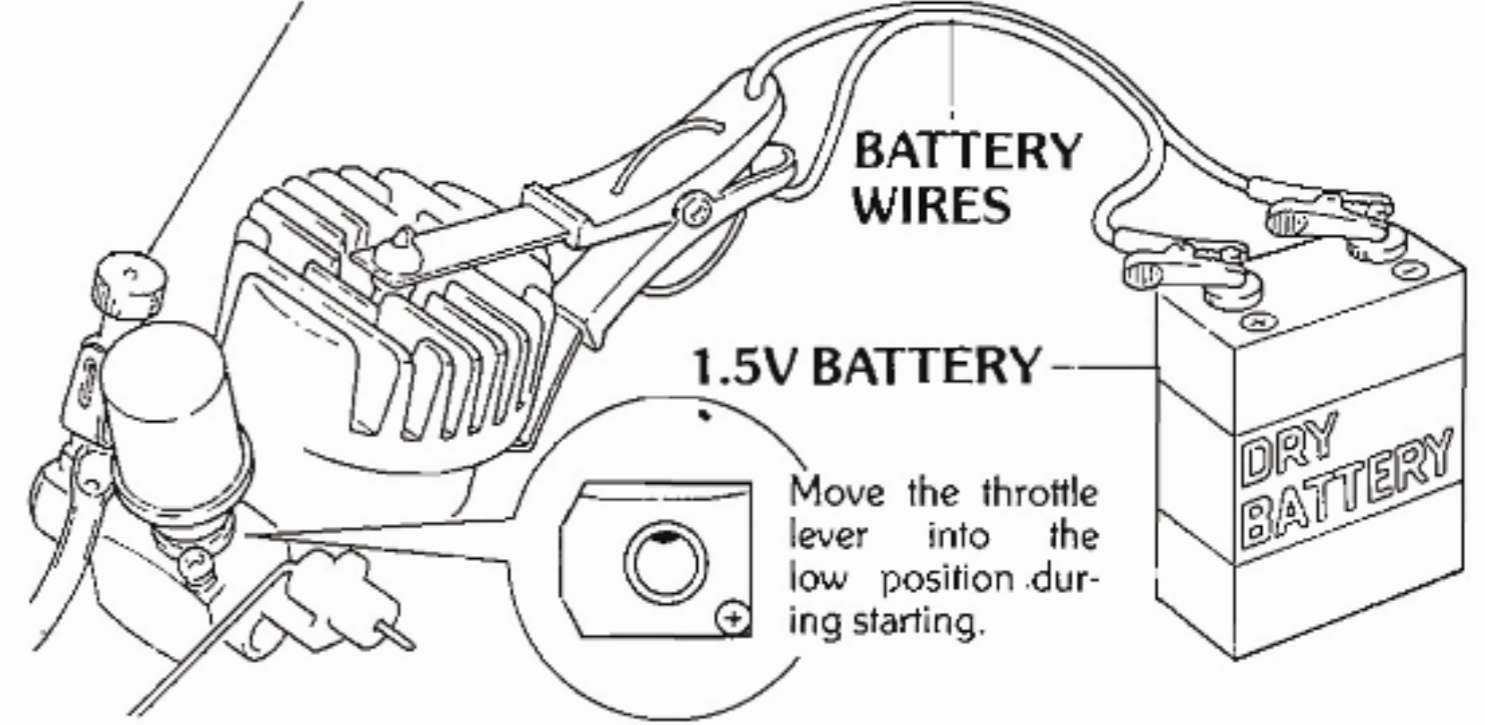

- 6 When using the zip starter, the body will need to be removed. Hold the model on its side as shown below. Insert the zip starter into the opening in the chassis. The teeth of the starter gear and the teeth of the zip starter should mesh together.

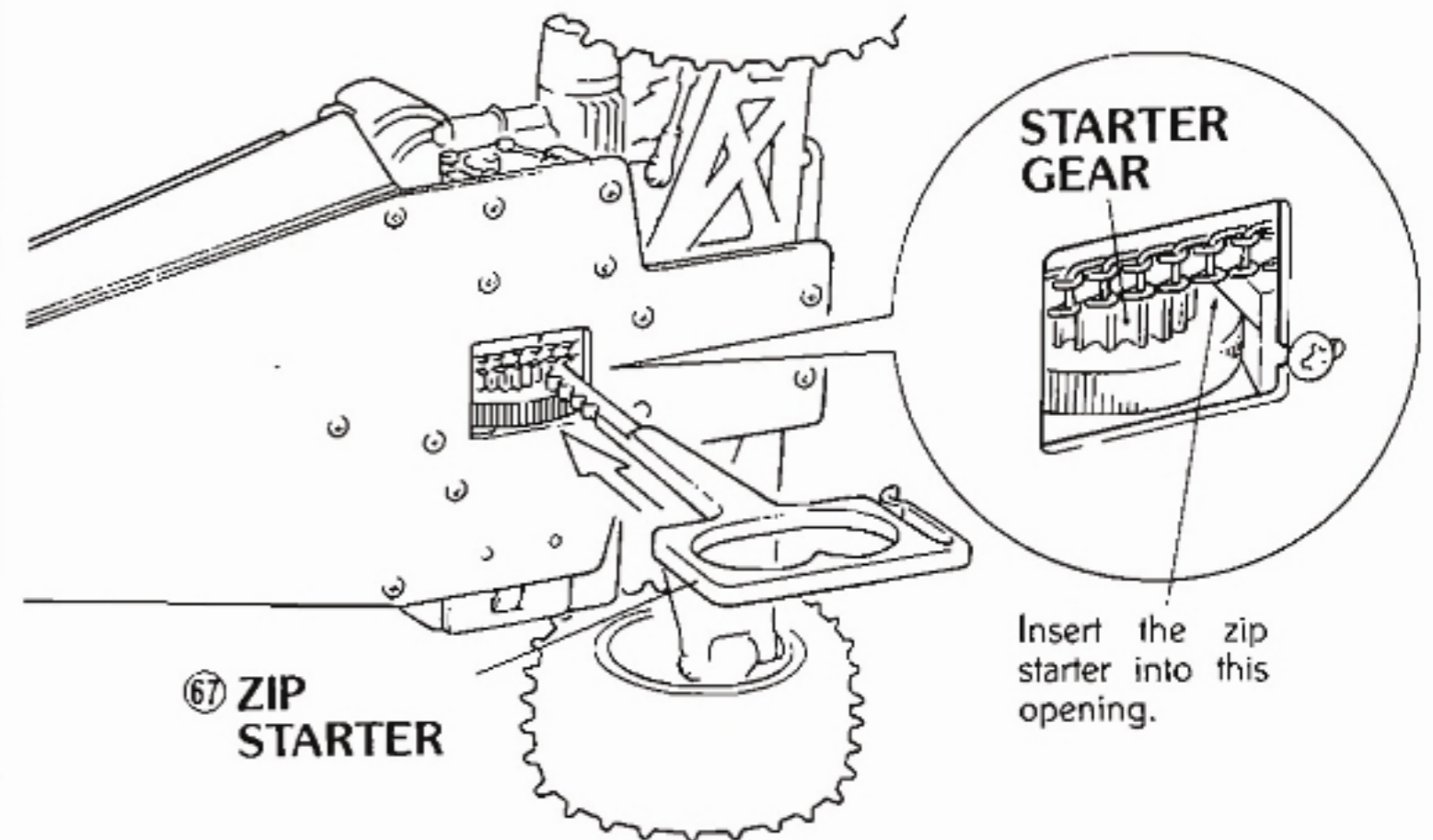

- 7 Then slowly pull the zip starter until you feel some resistance, pause a moment, then quickly pull the zip starter the rest of the way.

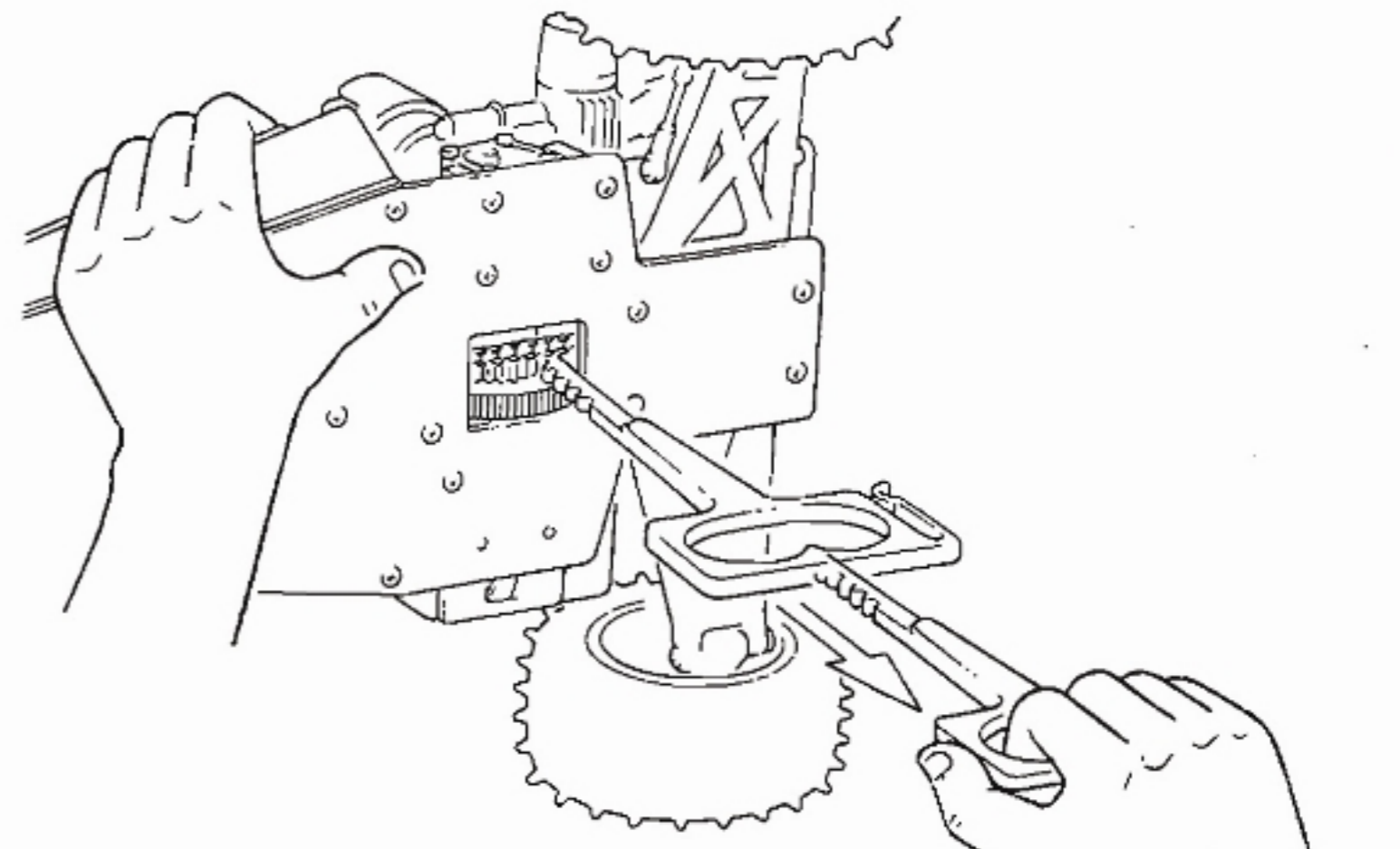

* You may need to do this several times. If you do not hear popping sounds while you are trying, prime the engine and repeat the starting procedure once the engine is started, adjust the needle valve according to the instruction manual that came with the engine.

HOW TO USE THE ELECTRIC STARTER

- For most type engines, you will need to obtain a starting wheel which attaches to your starter.
- O.S. CZ-1 engines, a helicopter starter extension may be used on the starting cone supplied with the engine, or the use of a wheel may be used as described below.

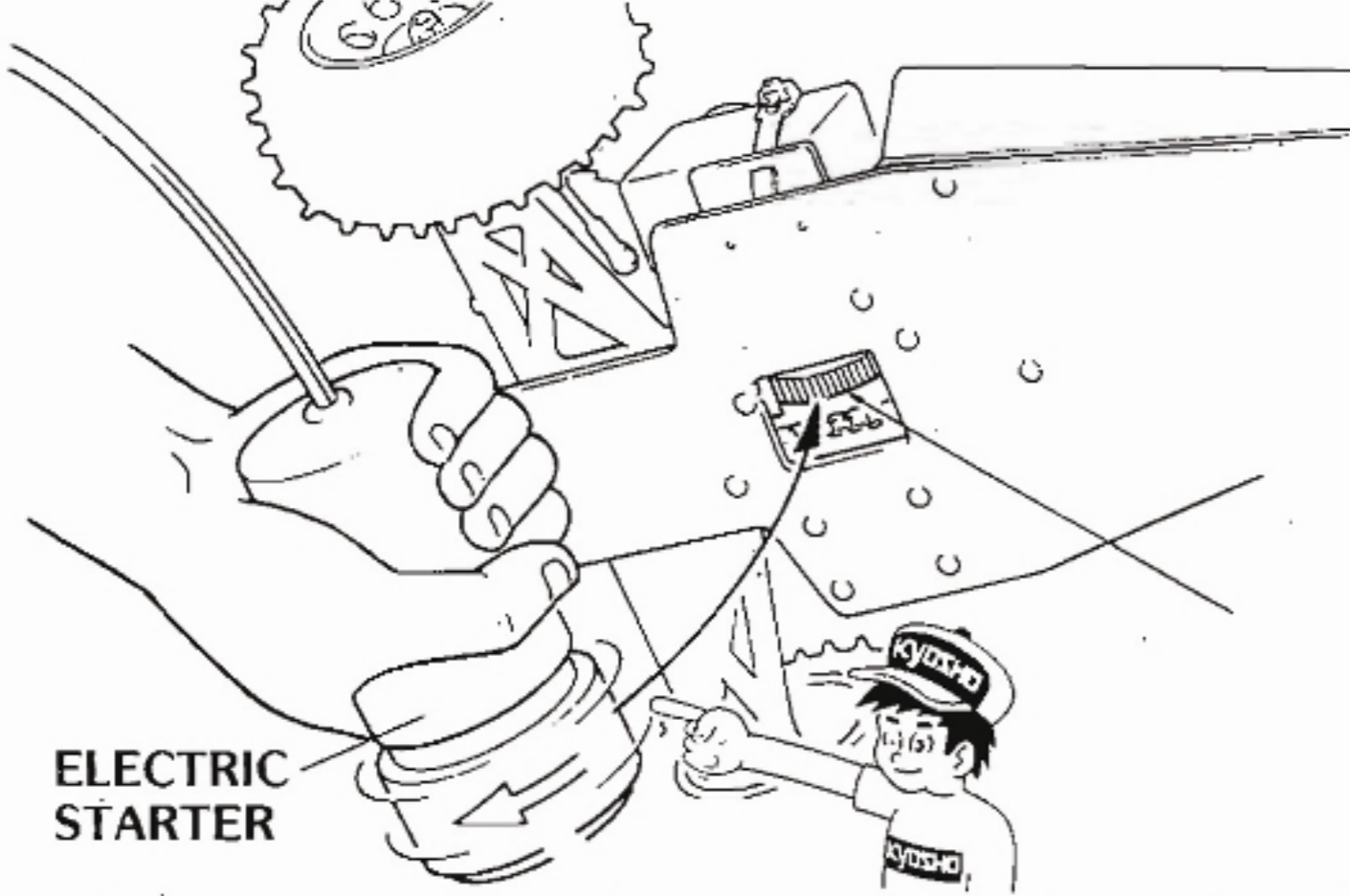

ELECTRIC STARTER

When using a starter on this car be very certain which way the starter is rotating the engine. These engines are designed and will only operate in one direction. The correct rotation of the engine is counter-clockwise while facing the engine from the clutch bell side of the engine. Use short, popping motions, while applying the starting wheel to the flywheel. Do not hold the starter on the flywheel for an extended period of time. If the engine has not started within the first few times, check the other components of the car using the trouble shooting diagram as a guide.

TROUBLE SHOOTING DIAGRAM

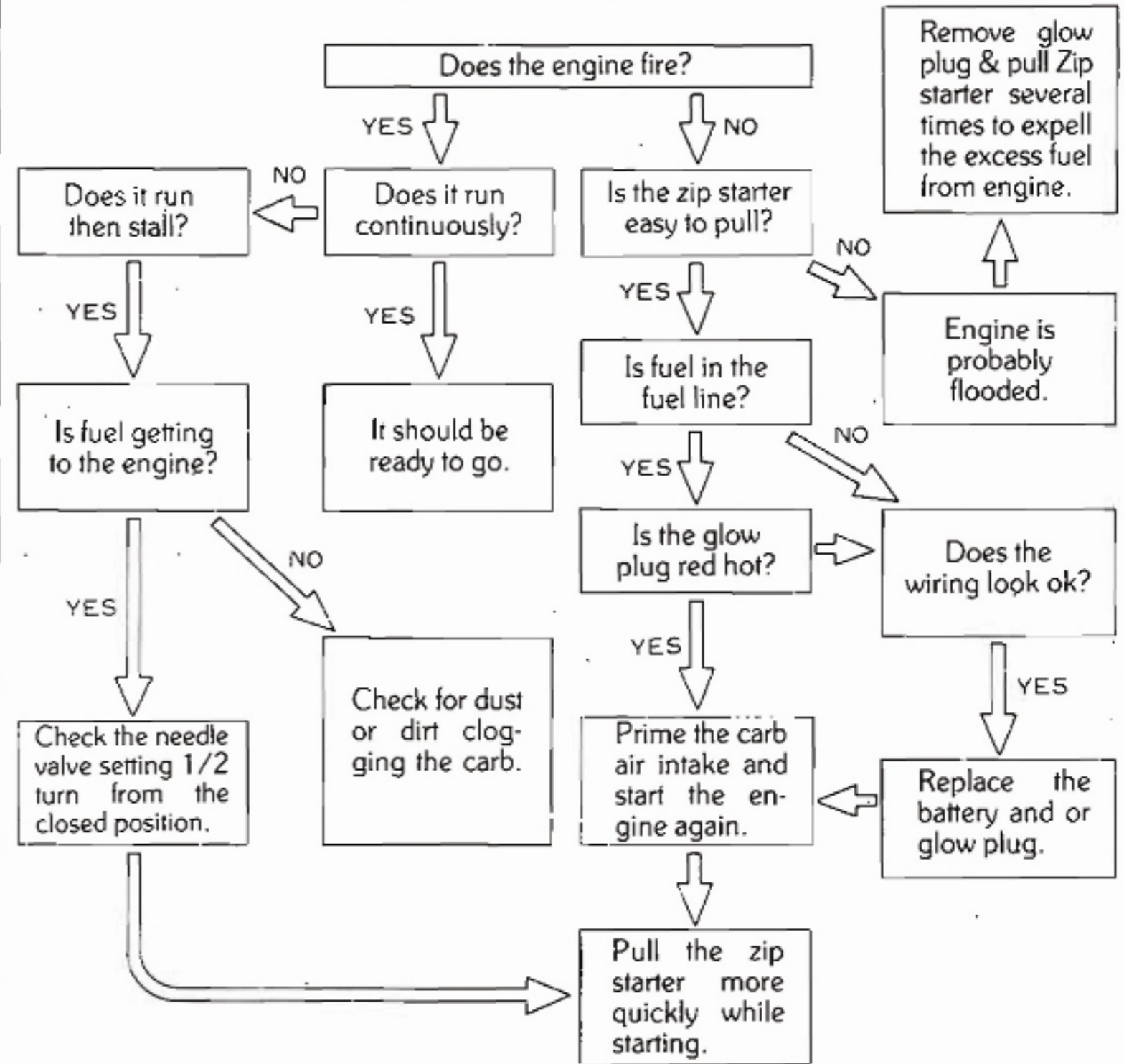

GUIDE TO KEY NUMBERS

① Joint 4	37 E Ring (E-2.5) 4	73 Needle Adapter (For Enya) . . . 1	109 Air Filter Holder 1
② 8mmx14mm Bearing 2	38 Ball End (L) 12	74 Pilot Shaft (For Enya) 1	110 Air Filter Adapter 1
③ Gear Box (R) 1	39 Upper Rod 4	75 Pilot Shaft (For OS) 1	111 Joint Plate 1
④ Gear Box (L) 1	40 Shock Seal 4	76 Engine Mount (A) (For Enya) . . 1	112 Side Cover (R) 1
⑤ Counter Gear 1	41 Shock End 4	77 Engine Mount (B) (For Enya) . . 1	113 Side Cover (L) 1
⑥ 5mmx10 Bushing (Gld Clr) . . 2	42 Shock Stopper 4	78 Engine Mount (C) (For OS) . . . 1	114 Body 1
⑦ Center Gear 1	43 Shock O Ring 4	79 Engine Mount (D) (For OS) . . . 1	115 Body Pin 2
⑧ 5mmx10 Bearing 1	44 Shock Washer 4	80 Muffler (A) 1	116 Center Gear Collar 1
⑨ Spur Gear Cone 1	45 Shock Oil 1	81 Muffler (B) 1	117 Muffler Baffle 1
⑩ Rear Plate 1	46 Shock Wrench 1	82 Clutch Shoe 2	118 Muffler Gasket 1
⑪ Rear Shock Stay 1	47 Front Shock Piston 2	83 Clutch Spring 1	119 Chassis 1
⑫ Stay 1	48 Rear Shock Piston 2	84 E Ring (E-7) 1	120 Radio Plate 1
⑬ M3 Pivot Ball (Silver Color) . . 12	49 Front Shock Case 2	85 Clutch Bearing 1 set	121 Radio Plate Mount 1
⑭ Bulk Head (R) 1	50 Rear Shock Case 2	86 Clutch Bell (14T) 1	122 Adapter Nut (For Enya) 1
⑮ Bulk Head (L) 1	51 Shock Bushing 4	87 E Ring (E-3) 1	123 Silicon Tube 1
⑯ Front Sus. Arm 2	52 Tie Rod 2	88 Roller Shaft 1	124 Antenna Tube 1
⑰ Sus. Shaft (A) 4	53 Rear Shaft 2	89 Chain Roller 1	125 Allen Wrench (1.5mm) 1
⑱ Bumper 1	54 Rear Hub (L) 1	90 Roller Mount 1	126 Allen Wrench (2mm) 1
⑲ Saver Shaft (A) 1	55 Rear Hub (R) 1	91 Gear Cover 1	127 Allen Wrench (2.5mm) 1
⑳ Saver Spring 1	56 Rear Sus. Arm 2	92 Tank Mount 1	128 Bushing Collar 2
㉑ Saver Crank (A) 1	57 Sus. Shaft (C) (Black Color) . . 2	93 Servo Mount 2	129 10mmx14 Bushing 2
㉒ Saver Crank (B) 1	58 Throttle Control Rod (B) . . . 1	94 Switch Cover 1	130 5mmx10 Bushing (Blk Clr) . . 8
㉓ Saver Crank (C) 1	59 5.8mm Ball 2	95 Body Mounting Post 1	131 Sprocket (A) 1
㉔ Saver Joint 1	60 Spur Gear (54T) 1	96 Joint Color 1	132 Sprocket (B) 1
㉕ Linkage Guide 1	61 Swing Shaft 4	97 Chain Adjuster 1	133 Sprocket (C) 1
㉖ 3mmx2 Aluminum Color . . . 1	62 Tire 4	98 Steering Rod 1	134 Bevel Gear (A) 4
㉗ E Ring (E-5) 2	63 Wheel (1) 4	99 Throttle Control Rod (A) . . . 1	135 Bevel Gear (B) 4
㉘ Saver Shaft (B) 1	64 Wheel (2) 4	100 Stopper 1	136 Bevel Gear Shaft 2
㉙ Knuckle Arm (R) 1	65 Wheel (3) 4	101 Fuel Tank 1	137 Bevel Main Gear 1
㉚ Knuckle Arm (L) 1	66 Drive Washer 4	102 Tank Bushing 1	138 Chain 1
㉛ Front Shaft 2	67 Zip Starter 1	103 Tank Pipe 1	139 Front Spring 2
㉜ Front Hub (R) 1	68 Flywheel 1	104 Packing 1	140 Rear Spring 2
㉝ Front Hub (L) 1	69 Clutch Pin 2	105 Cap 1	141 Spring Stopper 4
㉞ M2.6 Pivot Ball (Black Color) . 2	70 Starter Gear 1	106 Strap 2	142 Spring Holder 4
㉟ King Pin 4	71 Starter Claw 2	107 Receiver Cover 1	143 Brass Washer 1
㊱ Sus. Shaft (B) (Silver Color) . 2	72 Ratchet Spring 1	108 Air Filter Element 1	

PURCHASING PARTS FOR YOUR KIT

You can purchase replacement and optional parts for your kit. All of the parts identified by key numbers (see Page 22 for a complete list) are usually not available singularly, but we offer these parts in convenient parts "packs" which can be purchased separately. To figure out which parts pack you need, find the key number for that part within the

manual. Then consult our parts pack guide, below. When referring to the parts you need, always use the parts pack number. For instance, if you need a center gear (Key #7) ask your dealer for Kyosho Parts Pack SG-2 (Gear Set).

SPARE PARTS LIST

Parts Pack #	Description	Includes These Key Numbers	Parts Pack #	Description	Includes These Key Numbers
OT-04	King Pin	35 x 4	SG-20	Radio Plate	26 x 1
OT-05	Joint	1 x 2	SG-21	Plastic Gear Set	31 32 33 37 x 1
OT-06	Swing Shaft	61 x 2	SG-22	Screw Set	Screw, Nut, Wrench Set
OT-13	Suspension Arm Set	16 56 x 2	SD-79	Antenna Tube	24 x 5
OT-16	Knuckle Arm	29 30 x 1	OPTIONAL PARTS		
OT-17	Front Shaft	31 x 2			
OT-18	Rear Shaft	53 x 2	W-5031	Low Profile Tire (Hard)	For hard surface.
OT-19	Drive Washer	66 x 4	W-5032	Low Profile Tire (Soft)	For soft surface.
OT-28	Differential Gear Set	36 x 2 39 39 x 4	LD-26	Main Gear (52T)	Steel Gear
OT-31	M3 Pivot Ball	13 x 10	LD-27	Main Gear (53T)	Steel Gear
OT-32	5.8mm Ball	59 x 10	FM-82	Clutch Bell (11Z)	
OT-35	Upper Rod	39 x 4 38 x 8	SD-53	Clutch Bell (12Z)	
OT-36	M2.6 Pivot Ball	34 x 10	SD-54	Clutch Bell (13Z)	
OT-39	E-Ring (E-2.5)	37 x 10	1951	Shock Oil Set	Small, Medium, Hard x 3
OT-43	Rear Shock Set	46 x 1 40 41 42 43 44 48 50 51 59 60 61 62 x 2	1952	Differential Oil	
OT-45	Rear Hub	54 55 x 2			
OT-47	Front Hub	32 33 x 1			
OT-66	Low Profile Tire	62 x 2			
OT-67	Wheel for Low-Profile Tire	63 64 65 x 2			
AB-11	Muffler	80 81 117 118 x 1			
AB-12	Air Filter	108 109 110 x 1			
AB-13	Pilot Shaft (For Enya)	74 84 87 143 x 1			
AB-14	Pilot Shaft (For O.S.)	75 84 87 x 1			
AB-15	Clutch Shoe	82 x 2			
AB-16	Clutch Bell	86 x 1			
AB-17	Clutch Spring	83 x 4			
AB-27	Flywheel	68 x 1 69 x 2			
AB-28	Starter Gear Set	70 72 x 1 71 x 2			
AB-30	Front Shock	46 x 1 40 41 42 43 44 47 49 51 59 60 61 62 x 2			
EF-22	Hook Pin	115 x 5			
EF-39	NiCd Strap	106 x 6			
MB-63	Zip Starter	67 x 4			
LD-70	Clutch Bearing	85 x 1			
SC-89	Tie Rod	34 52 x 2 38 x 4			
KC-40	Main Gear	60 x 1			
FM-209	E Ring (E-5)	27 x 5			
1901	5mmx10mm Ball Bearing	8 x 2			
1911	8mmx14mm Bearing	2 x 2			
SG-01	Gear Box Set	3 4 10 14 15 x 1 93 x 2			
SG-02	Gear Set	5 7 9 16 17 18 19 20 x 1			
SG-03	Plate Set	11 111 x 1			
SG-04	Suspension Shaft	35 57 x 2 17 x 4			
SG-05	Linkage Set	25 26 58 98 99 x 1 100 x 2			
SG-06	Engine Mount (For Enya)	76 77 x 2			
SG-07	Engine Mount (O.S.-CZ1)	78 79 x 2			
SG-08	Tensioner Set	88 89 90 97 x 1			
SG-09	Bumper Set	12 18 x 1			
SG-10	Mount, Cover Set	91 92 94 107 x 1			
SG-11	Joint Collar Set	95 96 121 x 1			
SG-12	Servo Saver Set	19 20 21 22 23 24 28 x 1			
SG-13	Fuel Tank Set	101 102 103 104 105 123 x 1			
SG-14	Bushing Set	6 28 29 x 1 130 x 8			
SG-15	Chain	134 x 1			
SG-16	Needle Adapter	73 122 x 1			
SG-17	Side Cover	112 113 x 1			
SG-18	Body	114 x 1			
SG-19	Chassis	119 x 1			

YOUR R/C ENGINE

Please read through the instructions supplied with your engine before actually trying to run the Stinger.

A model engine is a precision machine. It will develop high power and performance when it is treated correctly; however it may not even rotate if it is handled incorrectly. What follows are a few tips on how to use your engine properly.

The engine's shaft must be able to rotate freely by hand with the glow plug removed. The engine is started by spinning the shaft. If there is anything impairing its smooth movement it will not start. When you install the engine be certain that the clutch and gears operate smoothly and don't bind. You should be able to spin the flywheel of the car with your hand (when the glow plug is removed.)

Engines run FAST. At their peak, most engines in this class turn at about 12,000 revolutions per minute (rpm); at idle 2,000 rpm can be expected. To start a model engine you must spin the shaft at least as fast as the minimum rpm that it will operate at. The ZIP-START system will allow you to do just this. Some people also use an electric starter pressed onto the rear cone.

The glow plug must be installed and in proper working order. Before attempting to start the engine, the plug must be heated (with battery power) to a point where the small coil becomes RED-HOT. This allows it to ignite the air/fuel mixture in the cylinder chamber. If the plug does not heat sufficiently, the engine will refuse to start. You can check the plug by removing it from the engine head and applying battery power to it as shown in the drawing to the right. Replace bad plugs with the short, standard (non-idle bar) type. Check the manufactures specifications for the type of glow plug that is recommended.

The amount of air-fuel mixture in the engine cylinder should be appropriate. Smooth operation is guaranteed only when the ratio of fuel to air is at the proper levels. FLOODING is the term used to describe when there is too much fuel (or not enough air) for the engine to run. This is probably the biggest cause of engines not starting.

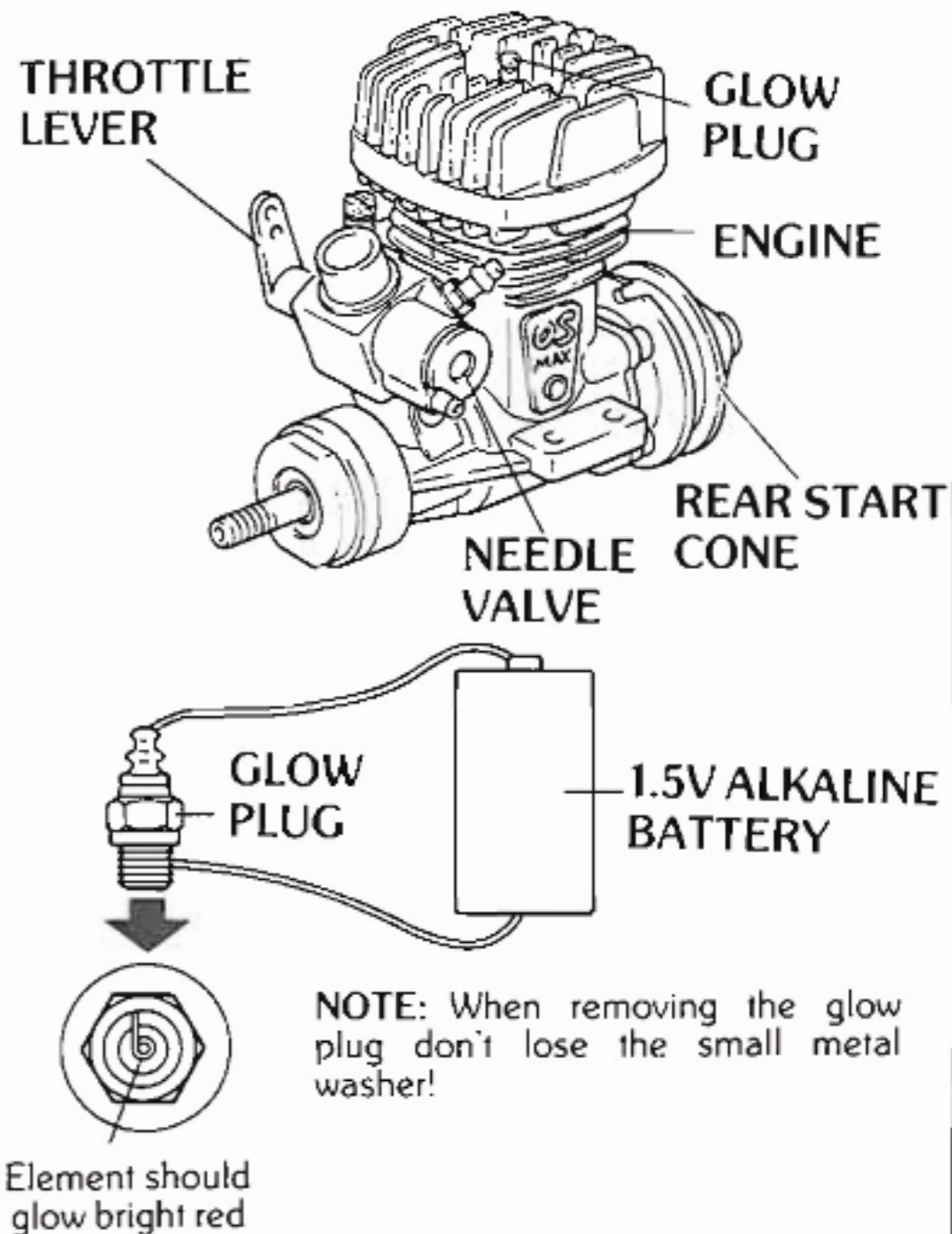

OPTIONAL PARTS

STINGER

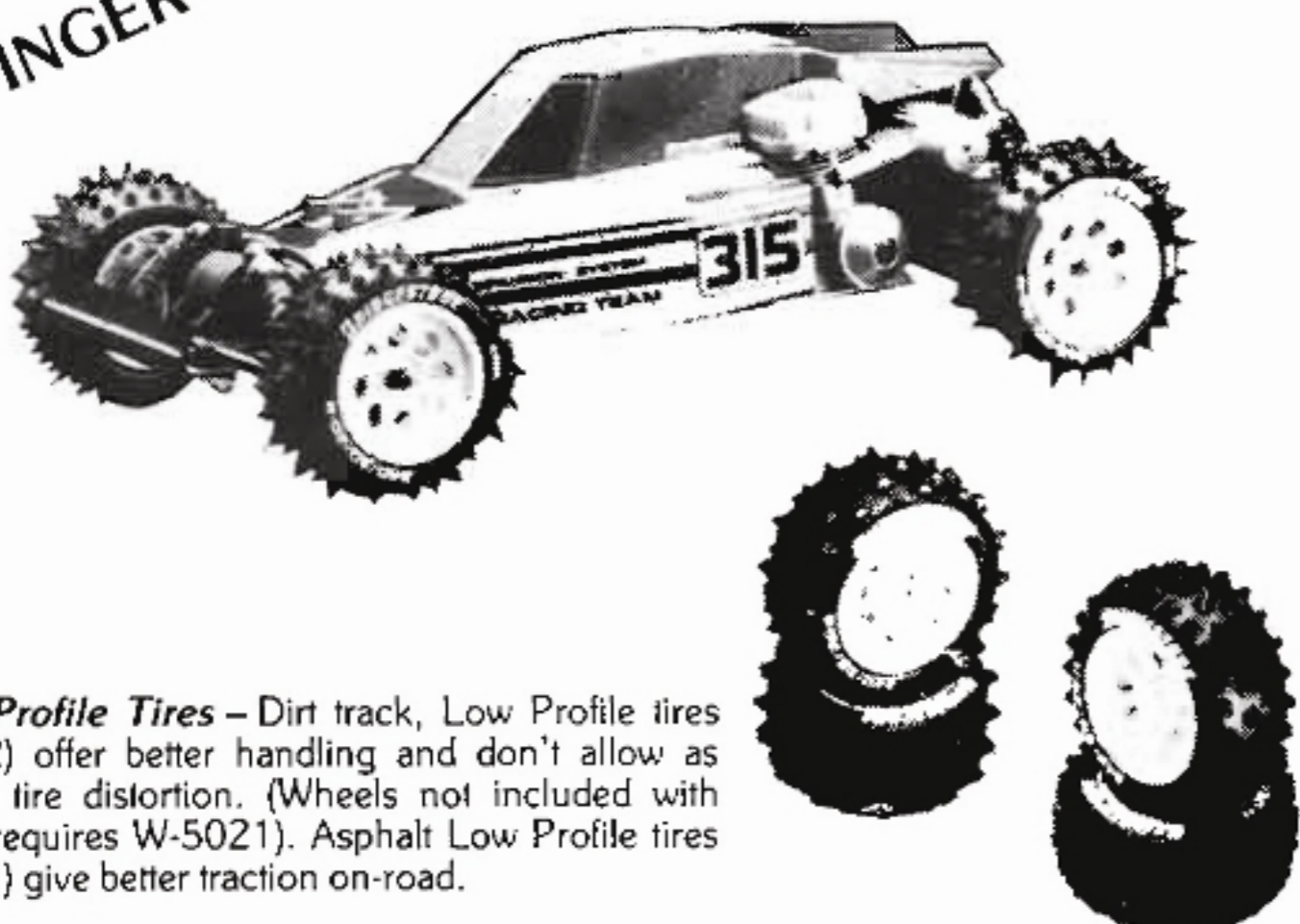

Low Profile Tires - Dirt track, Low Profile tires (5032) offer better handling and don't allow as much tire distortion. (Wheels not included with tires; requires W-5021). Asphalt Low Profile tires (5031) give better traction on-road.



Adjustable Pressure Shocks - Kyosho is famous for shocks and these are their best yet. Adjustable pressure shocks are available in both long and short versions, will fit most electric buggies and are completely adjustable for any track condition.

SUGGESTED FURTHER READING



A wealth of hints, tips and general information about R/C cars is available at your favorite hobby store. We suggest the "Completely Cars" book by Harry Higley which is packed with hundreds of photos and great "Tech-Tips". "R/C Car Action" a magazine published quarterly by Air-Age Publications will keep you on top of all the latest developments in the R/C car hobby.

KYOSHO

THE FINEST RADIO CONTROL MODELS

LIST OF BAGGED PARTS (1)

BLISTER PACK

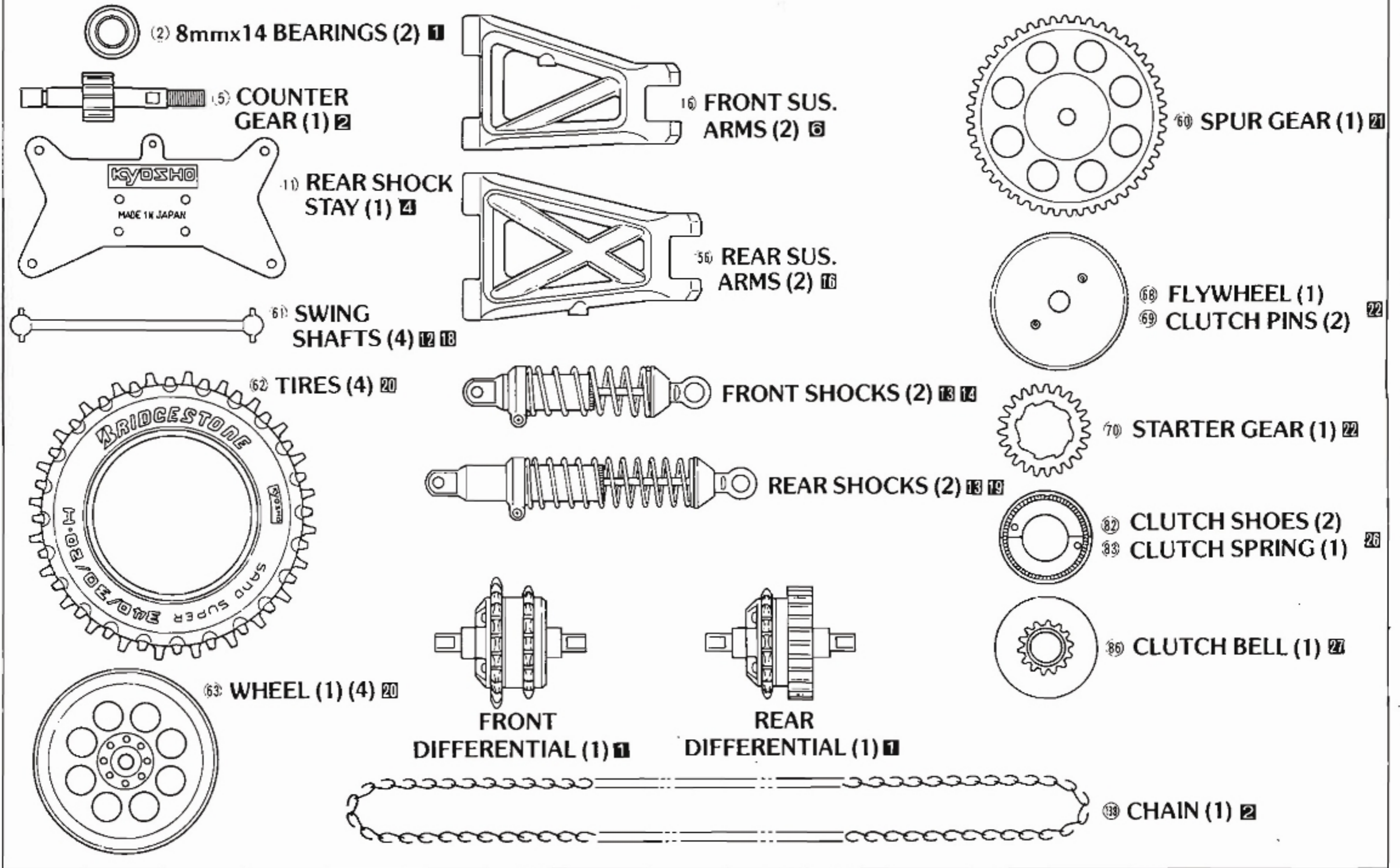

No. 1

- | | | | |
|--|--|---|--|
| <ul style="list-style-type: none"> • S/T SCREW M3x8 (10) M3x10 (12) M3x12 (13) M3x18 (5) M2x8 (16) | <ul style="list-style-type: none"> • SCREW M3x25 (1) M2.6x25 (2) M3x8 (14) M3x12 (4) M3x16 (3) | <ul style="list-style-type: none"> M3x45 (1) M3x55 (1) M4x40 (1) | <ul style="list-style-type: none"> • NUT M2.6 (2) M3 (4) • NYLON NUT M3 (5) M4 (1) M5 (1) M4 (5) |
|--|--|---|--|

- | | |
|--|--|
| <ul style="list-style-type: none"> • SET SCREW M3x4 (3) M3x4 (4) Silver M4x4 (5) M5x5 (1) | <ul style="list-style-type: none"> • FINER THREADED S/T SCREW M3x4 (2) • WASHER M2.6 (2) M3 (5) M5 (4) |
|--|--|

- (15) BODY PINS (2) ■
- (16) ALLEN WRENCH (1.5mm) (1) ■
- (17) ALLEN WRENCH (2mm) (1) ■
- (18) ALLEN WRENCH (2.5mm) (1) ■

No. 2

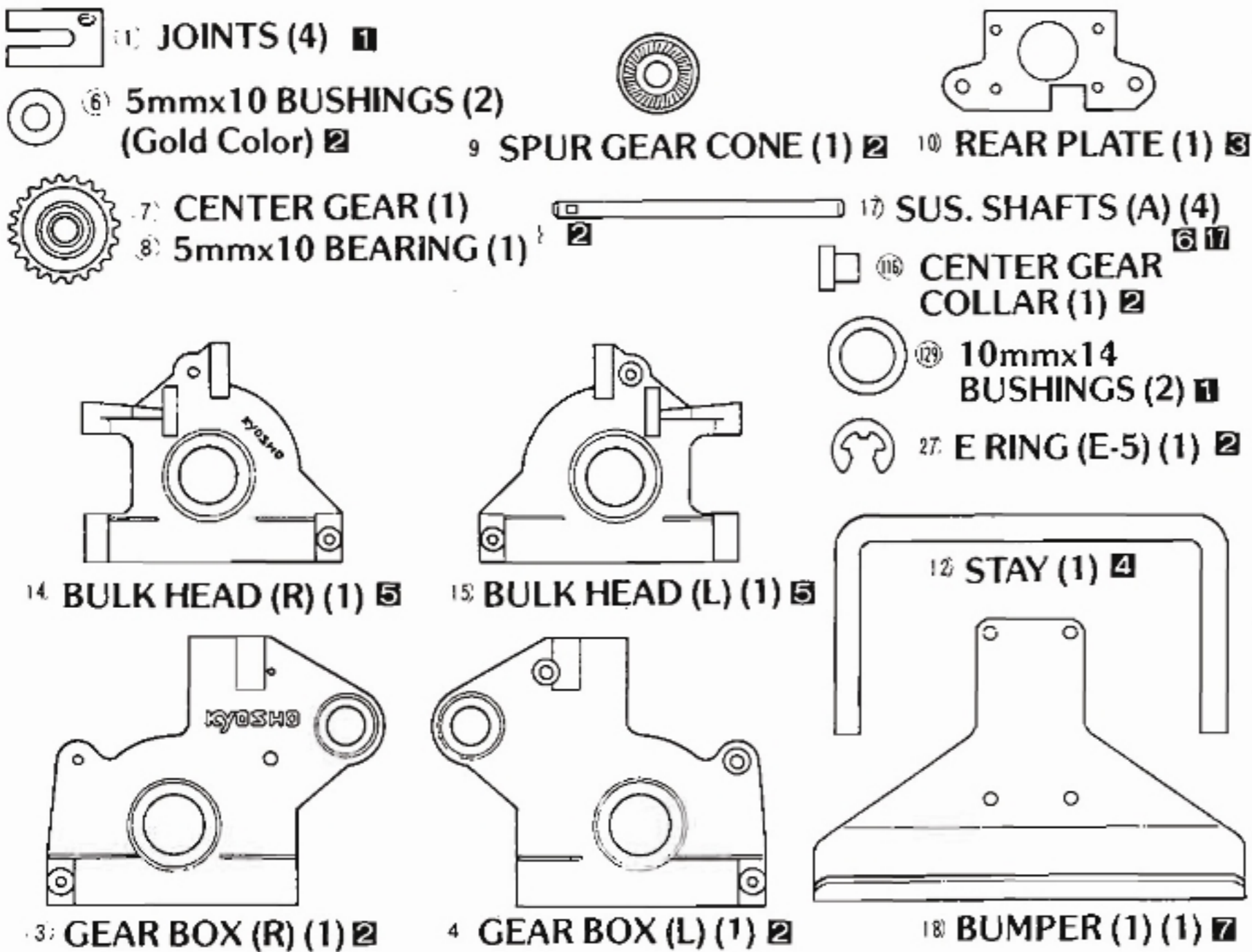

No. 3

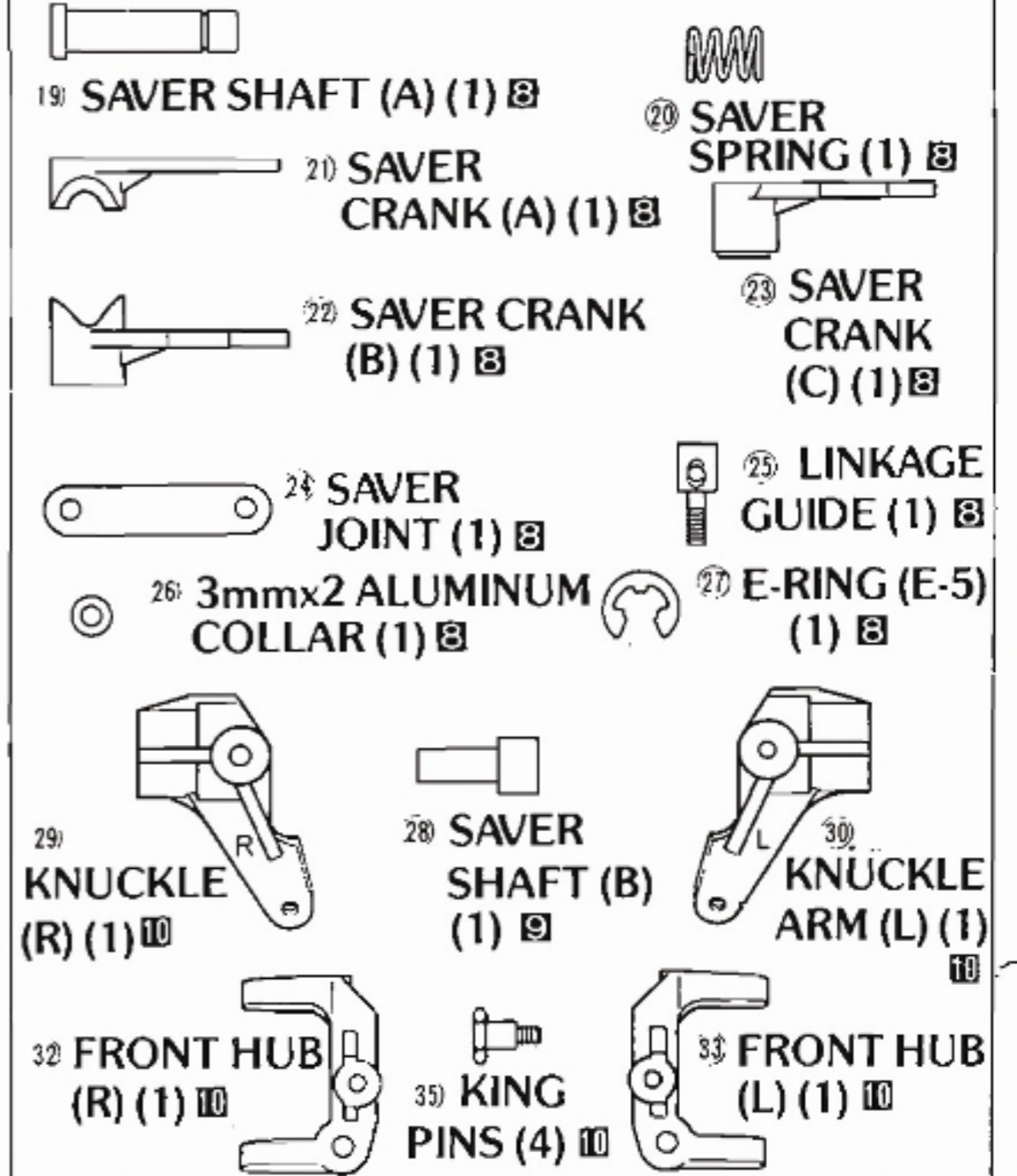

LIST OF BAGGED PARTS (2)

No. 4

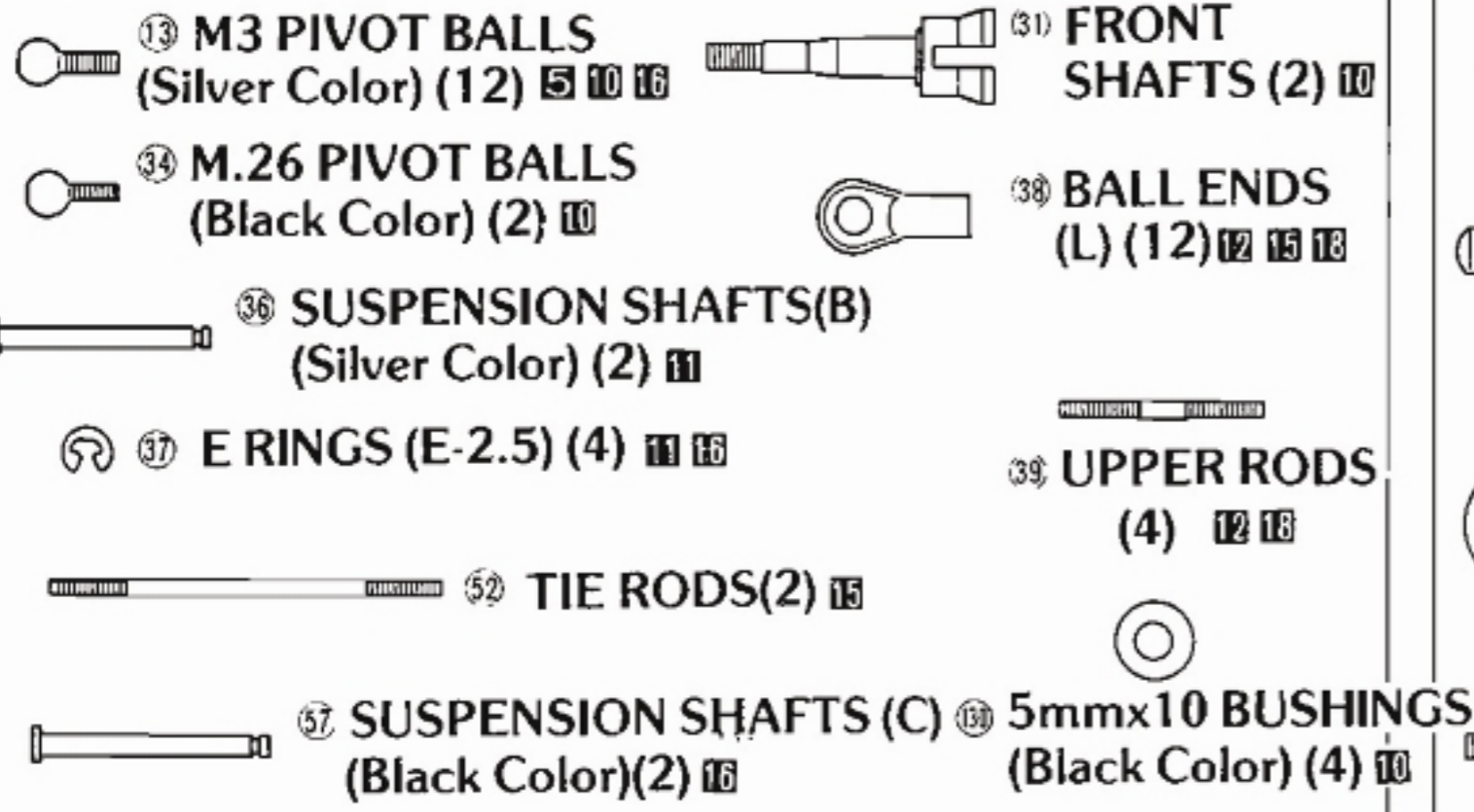

No. 5

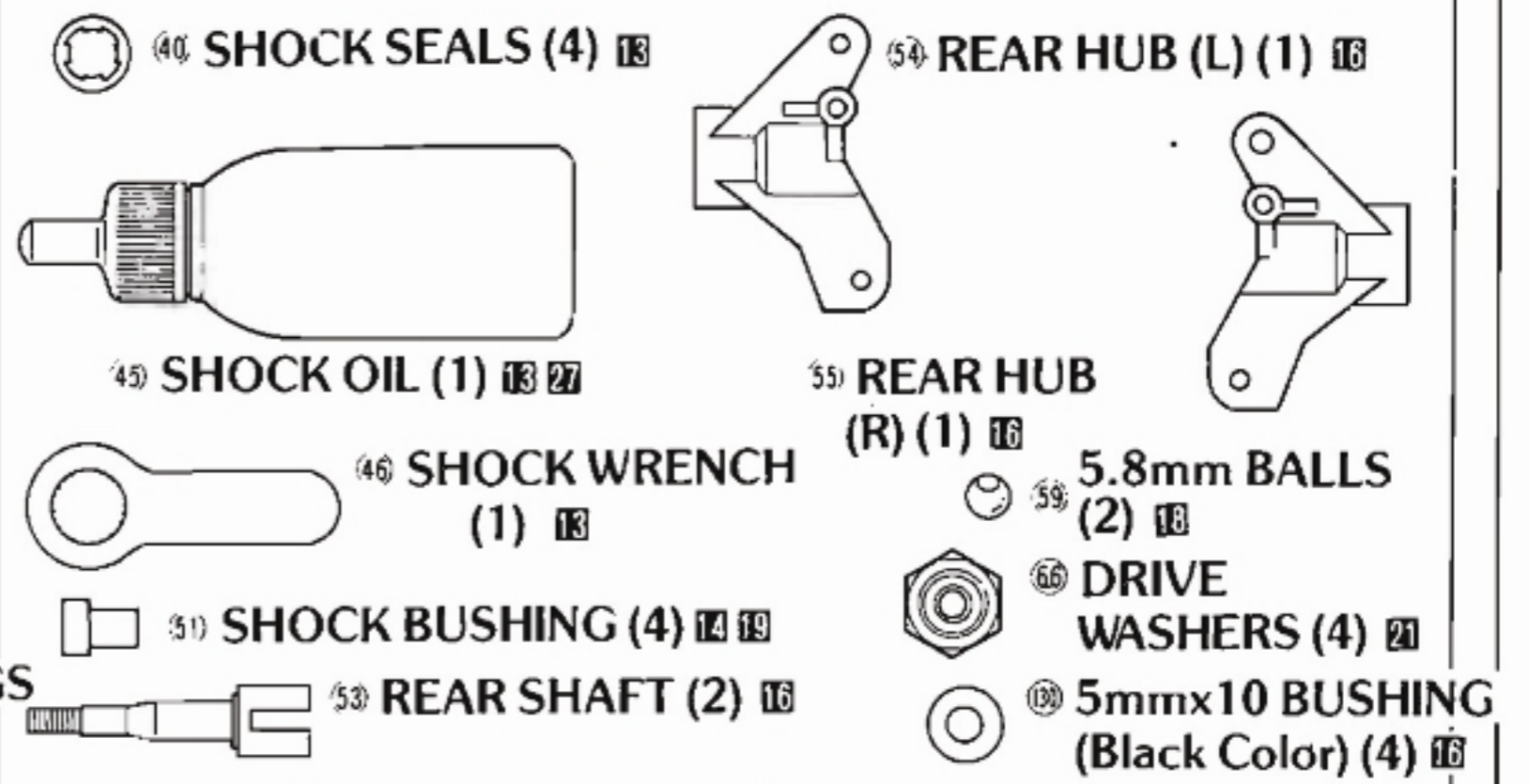

No. 6

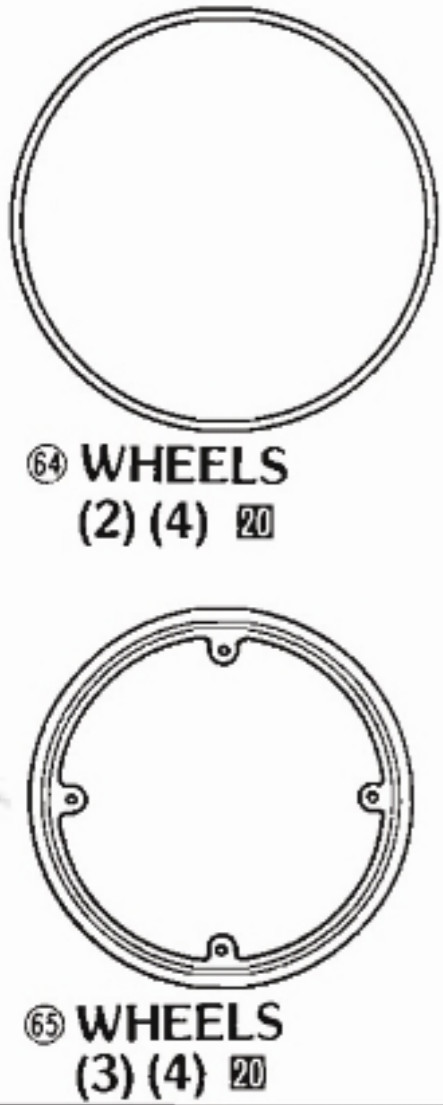

No. 7

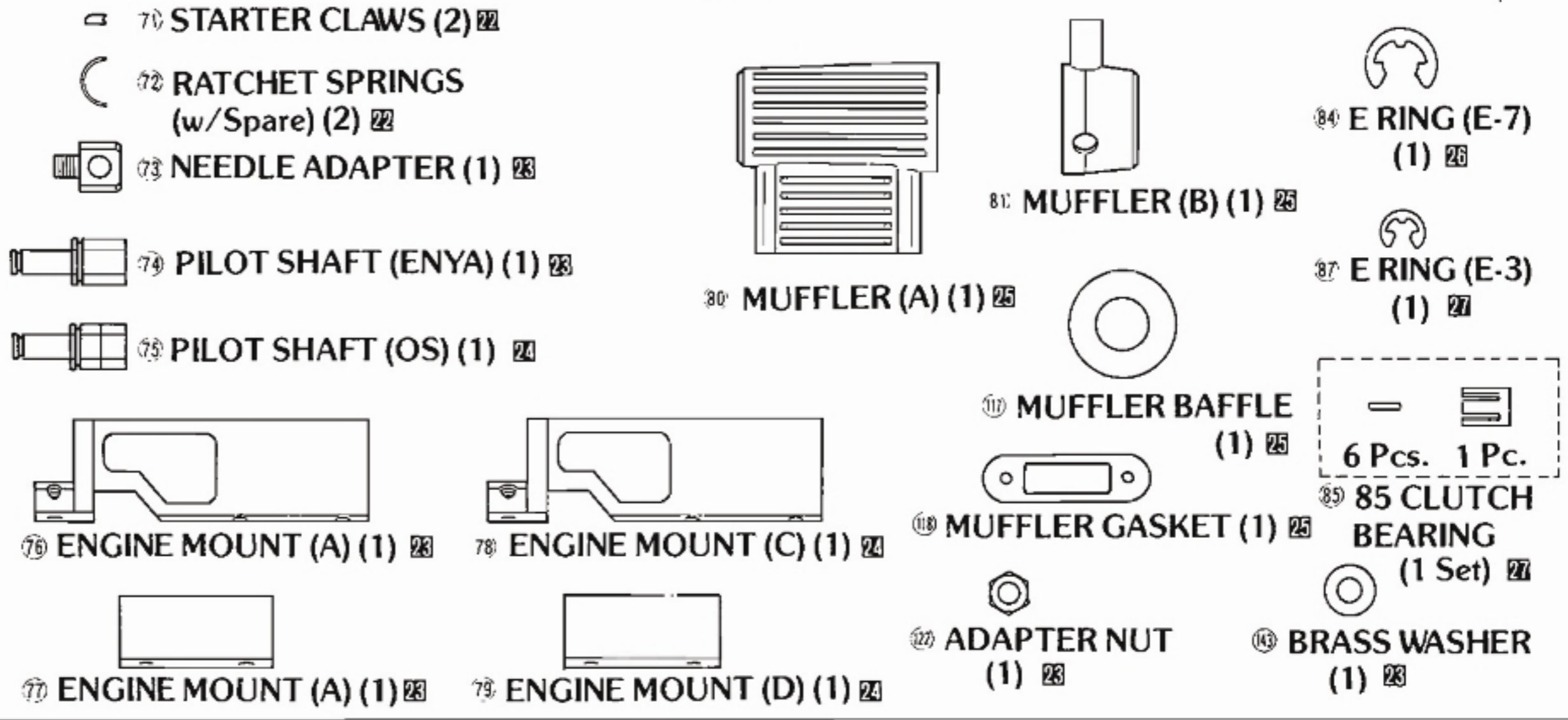

No. 8

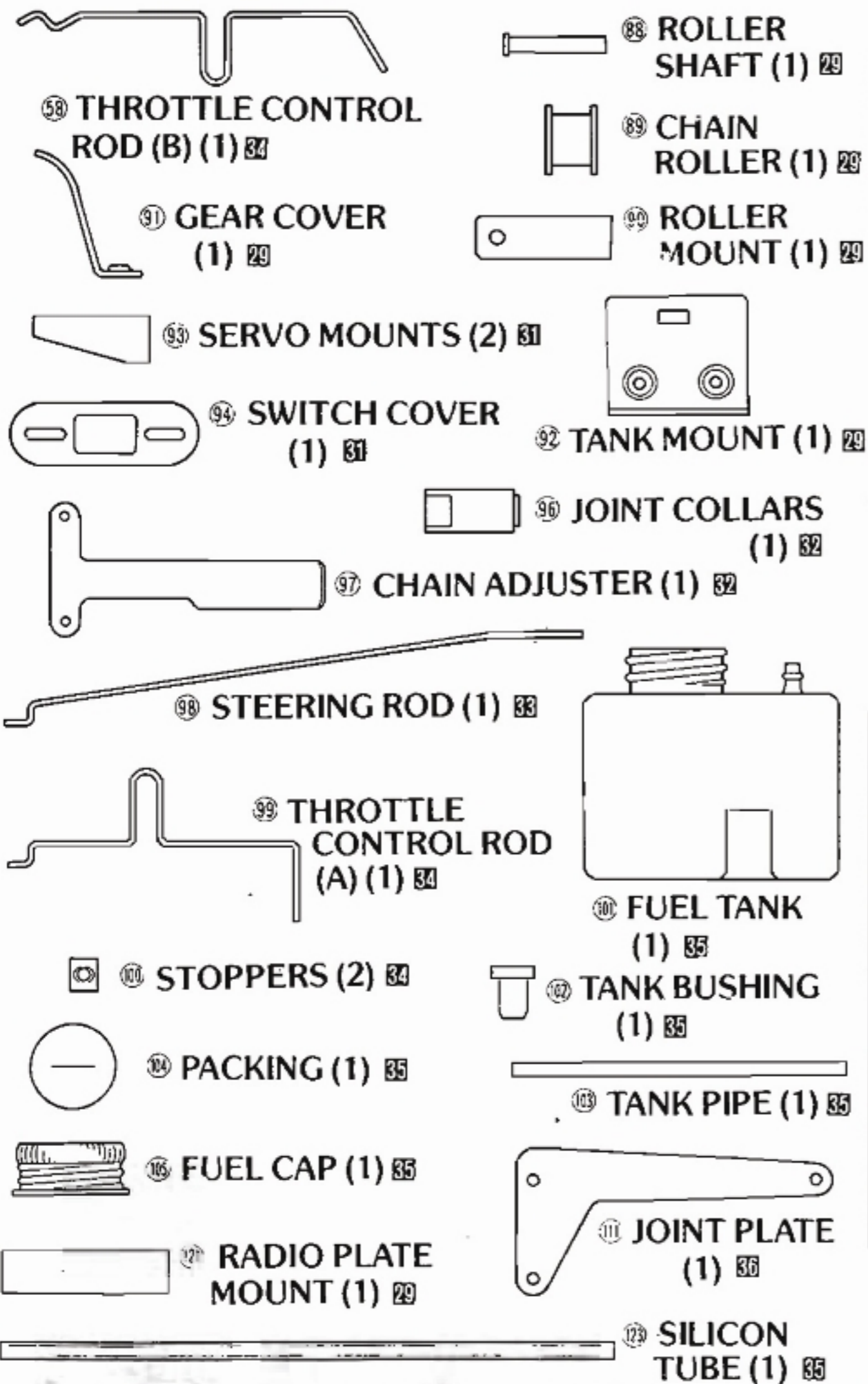

No. 9

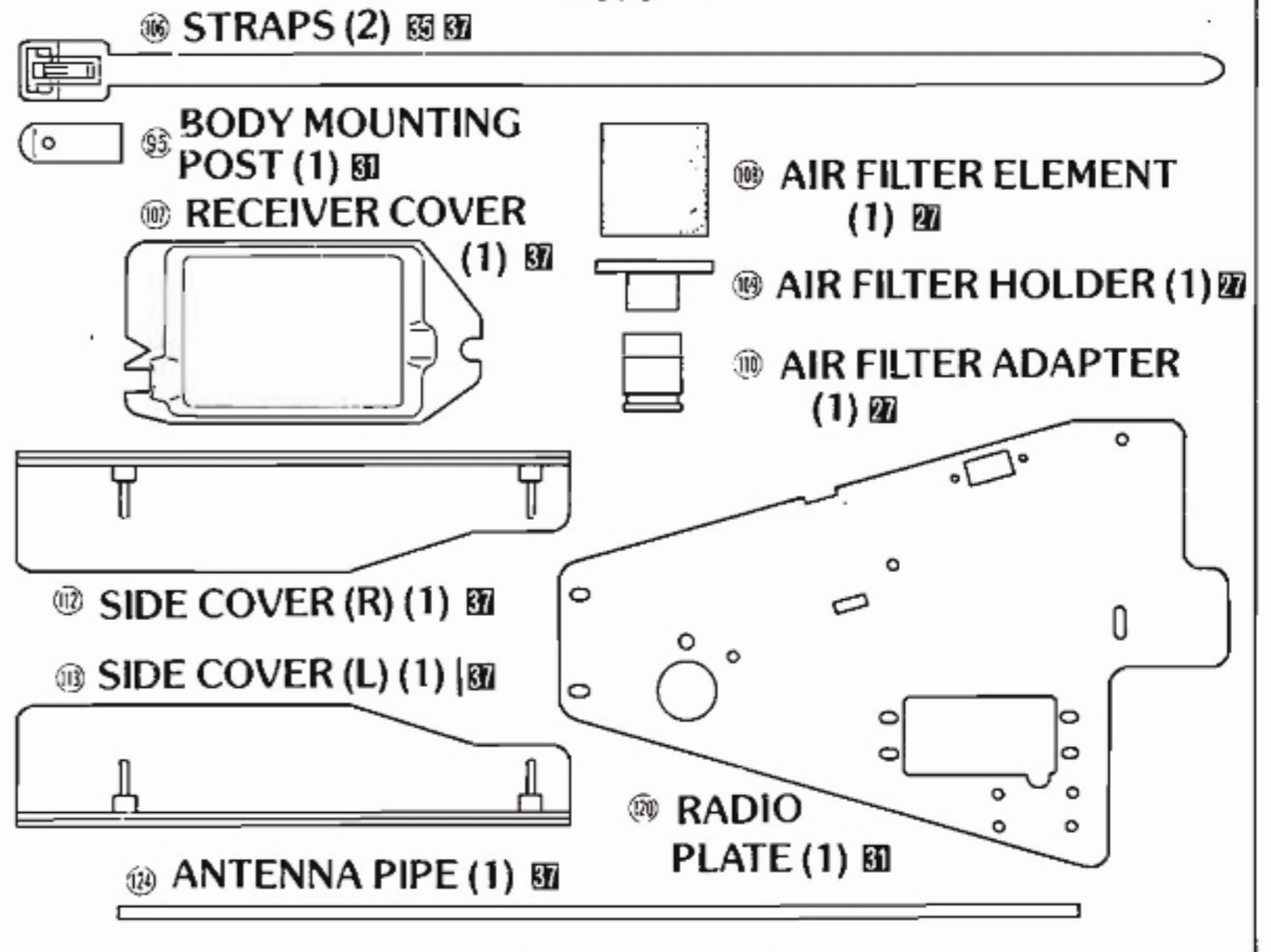

SMALL PARTS USED IN EACH ASSEMBLY STEP

1 INSTALLATION OF JOINT

M4x4 SET SCREWS (4) 

5mm WASHERS (4) 

① JOINTS (4) 

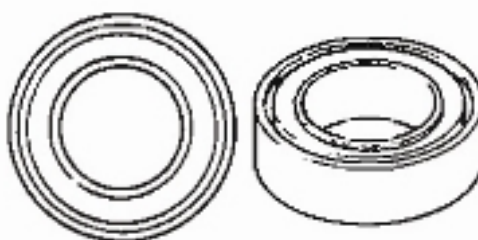
② 8mmx14 BEARING 

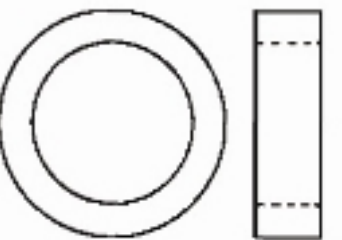
⑬ 10mmx14 BUSHINGS (2) 

2 INSTALLATION OF REAR GEAR BOX

M3x18 S/T SCREWS (2) 

M3x16 SCREW (1) 

M5x5 SET SCREW (1) 

M3 NUT (1) 

⑥ 5mmx10 BUSHINGS (Gold Color) 

⑨ SPUR GEAR CONE (1) 

⑳ E RING (E-5) (1) 

⑯ CENTER GEAR COLLAR (1) 

3 INSTALLATION OF REAR PLATE

M3x12 S/T SCREWS (4) 

4 INSTALLATION OF SHOCK STAY

M3x8 S/T SCREWS (4) 

M3x16 SCREWS (2) 

M3 NUTS (2) 

⑬ M3 PIVOT BALLS (2) (Silver Color) 

5 ASSEMBLY OF FRONT GEAR BOX

M3x18 S/T SCREWS (2) 

⑬ M3 PIVOT BALLS (2) (Silver Color) 

6 INSTALLATION OF FRONT SUSPENSION ARM

M3x4 SET SCREWS (2) (Silver Color) 

⑰ SUSPENSION SHAFT (A) (2) 

7 INSTALLATION OF CHASSIS

M3x12 S/T SCREWS (8) 

8 ASSEMBLY OF SERVO SAVER

M3 NYLON NUT (1) 

⑬ M3 PIVOT BALLS (2) (Silver Color) 

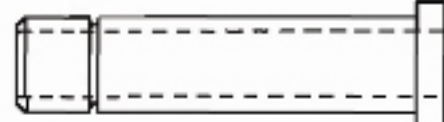
⑰ SAVER SHAFT (A) (1) 

⑳ SAVER SPRING (1) 

㉔ SAVER JOINT (1) 

㉕ LINKAGE GUIDE (1) 

㉖ 3mmx2 ALUMINUM COLLAR (1) 

㉗ E RING (E-5) 

9 INSTALLATION OF SERVO SAVER

M3x25 SCREW (1) 

M4x40 SCREW (1) 

M3 NUT (1) 

M4 NUT (1) 

M4 NYLON NUT (1) 

M3 WASHER (1) 

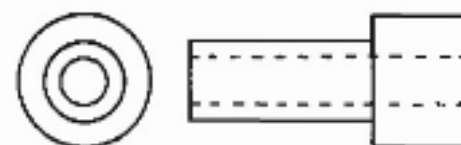
㉘ SAVER SHAFT (B) (1) 

10 ASSEMBLY OF KNUCKLE ARM

M2.6 NUTS (2) 

⑬ 5mmx10 BUSHINGS (4) (Black Color) 

⑬ M3 PIVOT BALLS (4) (Silver Color) 

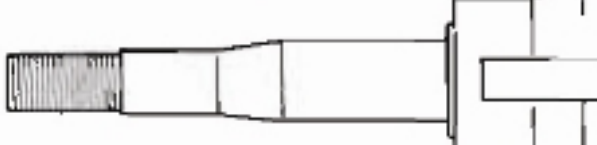
⑳ FRONT SHAFTS (2) 

㉙ M2.6 PIVOT BALLS (2) (Black Color) 

㉚ KING PINS (4) 

11 INSTALLATION OF KNUCKLE ARM

⑳ SUSPENSION SHAFTS (B) (2) (Silver Color) 

㉗ E RINGS (E-2.5) (2) 

12 INSTALLATION OF FRONT UPPER ROD

⑳ BALL ENDS (L) (4) 

㉙ UPPER RODS (2) 

13 FILLING SHOCK WITH OIL

⑳ SHOCK SEALS (4) 

㉙ SHOCK ENDS (4) 

㉚ SHOCK O RINGS (4) 

㉛ SHOCK WASHERS (4) 

14 INSTALLATION OF FRONT SHOCK

M3x12 SCREWS (2) 

㉜ SHOCK BUSHING (2) 

15 INSTALLATION OF TIE ROD

⑳ BALL ENDS (L) (4) 

㉜ TIE RODS (2) 

16 INSTALLATION OF REAR HUB

⑬ M3 PIVOT BALLS (2) (Silver Color) 

㉗ E RINGS (E-2.5) (2) 

㉜ Rear SHAFTS (2) 

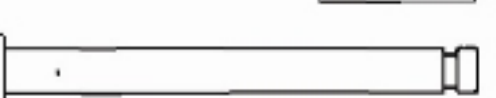
㉜ SUSPENSION SHAFTS (2) (Black Color) 

⑬ 5mmx10 BUSHINGS (4) (Black Color) 

17 INSTALLATION OF REAR SUSPENSION ARM





M3x4 SET SCREWS (2) (Silver Color) 

⑰ SUSPENSION SHAFTS (A) (2) 

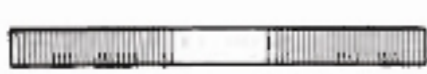

SMALL PARTS USED IN EACH ASSEMBLY STEP

18 INSTALLATION OF REAR UPPER ROD

- M3x12 SCREWS (2) 
- 38 BALL ENDS (L) (4) 
- 39 UPPER RODS (2) 
- 59 5.8mm BALLS (2) 

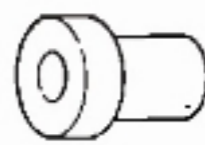

19 INSTALLATION OF REAR SHOCK

- M3 NYLON NUTS (2) 
- 51 SHOCK BUSHING (2) 



20 MOUNTING THE WHEEL AND TIRE

- M2x8 S/T SCREWS (16) 

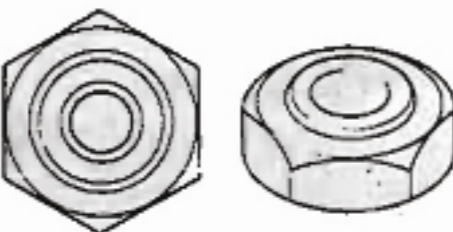



21 INSTALLATION OF TIRES AND SPUR GEAR

- M4 NYLON NUTS (4) 
- M5 NUT (1) 
- 66 DRIVE WASHERS (4) 

22 ASSEMBLY OF FLYWHEEL

- 71 STARTER CLAWS (2) 
- 71 RATCHET SPRINGS (2) 

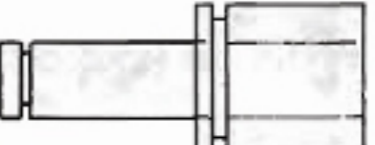

23 INSTALLATION OF ENGINE MOUNT

- M3x8 SCREWS (4) 
- 73 NEEDLE ADAPTER (1) (Enya-11CX) 
- 74 PILOT SHAFT (1) (For Enya) 
- 122 ADAPTER NUT (1) (Enya-11CX) 
- 143 BRASS WASHER (1) (Enya-11CX) 

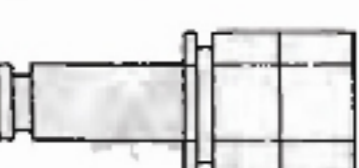
24 INSTALLATION OF ENGINE MOUNT

- M3x8 SCREWS (4) 
- 75 PILOT SHAFT (1) (For OS) 





25 INSTALLATION OF MUFFLER

- M2.6x25 SCREWS (2) 
- M3x55 SCREW (1) 

26 INSTALLATION OF CLUTCH

- 84 E RING (E-7) (1) 

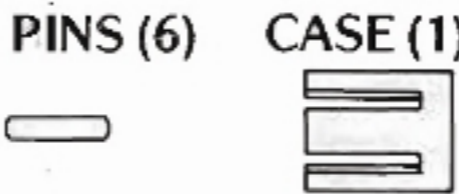
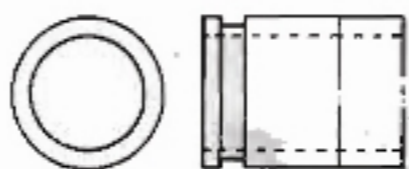







27 INSTALLATION OF CLUTCH BELL AND AIR FILTER

- 5mm WASHER (1) 
- 8mm WASHER (1) 
- 85 CLUTCH BEARING PINS (6) CASE (1) 
- 110 AIR FILTER ADAPTER (1) (Black Rubber) 
- 87 E RING (E-3) (1) 

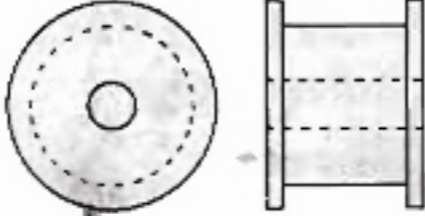
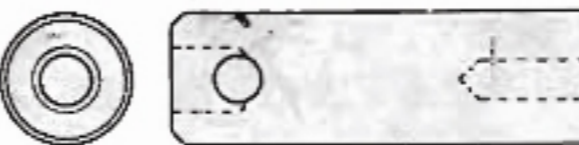

28 MOUNTING OF ENGINE

- M3x8 SCREWS (5) 



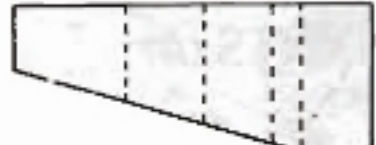
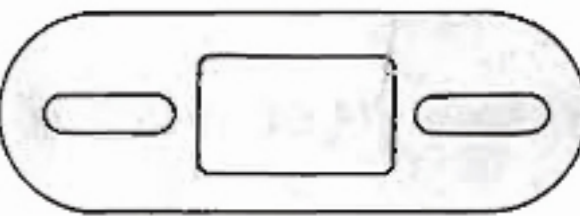
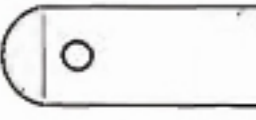

29 INSTALLATION OF CHAIN GUIDE

- M3x4 FINER THREADED S/T SCREWS (2) 
- M3x8 SCREWS (2) 
- M3x45 SCREW (1) 
- M4x4 S/T SCREW (1) 
- M3 WASHERS (2) 
- 88 ROLLER SHAFT (1) 
- 89 CHAIN ROLLER 
- 90 ROLLER MOUNT (1) 
- 121 RADIO PLATE MOUNT (1) 

31 INSTALLATION OF SERVO

- M3x8 SCREW (1) 
- M3x10 S/T SCREW (10) 
- M2.6 WASHERS (2) (Black Color) 
- 93 SERVO MOUNTS (2) 
- 94 SWITCH COVER (1) (Black Rubber) 
- 95 BODY MOUNTING POST (1) 



32 MOUNTING RADIO PLATE

- M3x10 S/T SCREWS (2) 
- M3x12 S/T SCREW (1) 
- M3 WASHERS (2) 
- 96 JOINT COLLAR (1) 

33 STEERING CONTROL LINKAGE

- M3x4 S/T SCREW (1) 



34 ENGINE CONTROL LINKAGE

- M3x4 SET SCREWS (2) 
- 100 STOPPERS (2) 

35 INSTALLATION OF FUEL TANK

- 107 TANK BUSHING (1) 

36 INSTALLATION OF JOINT PLATE

- M3x8 SCREW (1) 
- M3x8 S/T SCREWS (2) 

37 INSTALLATION OF RECEIVER COVER AND SIDE COVER

- M3x8 S/T SCREWS (4) 

40 MOUNTING OF BODY

- 115 BODY PINS (2) 

STINGER 4WD

STINGER 4WD

STINGER 4WD

STINGER 4WD

STINGER 4WD

STINGER 4WD

CIRCUIT 1000 SERIES

CIRCUIT 1000 SERIES

SUPER SUSPENSION SYSTEM

SUPER SUSPENSION SYSTEM

SUPER SUSPENSION SYSTEM

SUPER SUSPENSION SYSTEM



PRINTED IN JAPAN

FOUR WHEEL DRIVE

FOUR WHEEL DRIVE

FOUR WHEEL DRIVE

FOUR WHEEL DRIVE



BRIDGESTONE

BRIDGESTONE

BRIDGESTONE

BRIDGESTONE

ENGINE & MACHINE TUNE

ENGINE & MACHINE TUNE



1/10 BUGGY OFF ROAD RACE CAR

1/10 BUGGY OFF ROAD RACE CAR



KYOSHO

KYOSHO RACING TEAM

KYOSHO RACING TEAM



KYOSHO RACING TEAM

KYOSHO RACING TEAM